

3M 1800 Overhead Projector

Illustrated Parts Breakdown

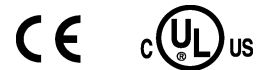
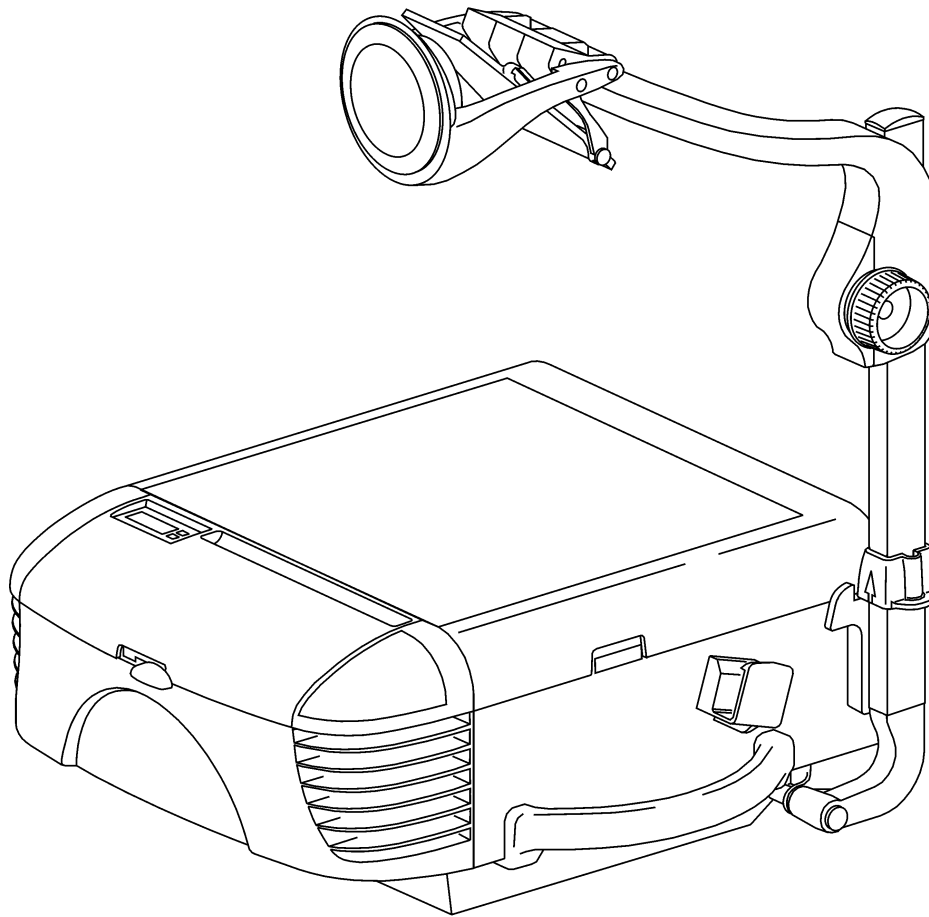

Revision History

Original Issue date: 10/2001

The release date, revision level, pages changed and a description of the modifications are listed below.

Revision	Date	Page(s) Changed	Description
Rev A	10/2001	All pages	First edition released
Rev B	1/2002	Figure 1	Added Light Shield Kit
Rev C	6/2002	All pages	Individual parts combined into modules and kits
Rev D	8/2002	Figures 5, 8-14	Added Post Handle, Lamp Module kit content, OUS motor, and U.S. Roll Film Kit.
Rev E	6/2003	All pages	New art and parts listings for kits, modules, and individual parts.
Rev F	10/2004	All pages	Figure numbers and most tables have new layout.
		Section 4, Page 9	New Arm Kit names and part numbers.
		Section 5, Pages 10 and 11	New Arm section added for S/Ns above 18040828.
		Section 7, Page 14	Added On/Off Button Kit to Top Cover art.
		Section 8, Pages 16 and 17	New Top Cover section added for clipped-in glass.
		Section 18, Page 29	New 120V Fan Motor name and part number.
		Section 19, Page 31	New 120V and 230V Fan Motor names and part numbers.
Appendix A	New information added.		

All rights reserved. No part of this book covered by the copyrights hereon may be reproduced or copied in any form or by any means-graphic, electronic, or mechanical, including photocopying, taping or information storage and retrieval systems-without written permission of 3M Visual Systems Division.

Table of Contents

TABLE OF CONTENTS0
 ILLUSTRATED PARTS BREAKDOWN (IPB) 1
 QUICK REFERENCE PARTS INDEX2
 SECTION 0. MACHINE OVERVIEW3
 SECTION 1. INVERTED HEAD ASSEMBLY.....4
 SECTION 2. OPEN HEAD ASSEMBLY5
 SECTION 3. CLOSED HEAD ASSEMBLY6
 SECTION 4. ARM ASSEMBLY (SERIAL NUMBER 18040827 AND BELOW)8
 SECTION 5. ARM ASSEMBLY (SERIAL NUMBER 18040828 AND ABOVE)10
 SECTION 6. POST MOUNTING HARDWARE.....12
 SECTION 7. TOP COVER ASSEMBLY (WITH TAPED-IN STAGE GLASS)14
 SECTION 8. TOP COVER ASSEMBLY (WITH CLIPPED-IN STAGE GLASS).....16
 SECTION 9. BASE ASSEMBLY18
 SECTION 10. LAMP HOUSING (SINGLE ENX/FXL).....20
 SECTION 11. LAMP HOUSING (DUAL ENX/FXL).....21
 SECTION 12. LAMP HOUSING (SINGLE FNT).....22
 SECTION 13. LAMP HOUSING (DUAL FNT)23
 SECTION 14. LAMP HOUSING (DUAL EVD)24
 SECTION 15. LAMP ASSEMBLY.....25
 SECTION 16. COOLING FAN ASSEMBLY.....26
 SECTION 17. ROLL FILM KIT27
 SECTION 18. WIRE JUMPERS (ENX AND FXL)28
 SECTION 19. WIRE JUMPERS (EVD AND FNT)30
 SECTION 20. PLASTIC PARTS KIT32
 SECTION 21. SMALL ELECTRICAL PARTS KIT.....32
 SECTION 22. HARDWARE KIT.....33
 APPENDIX A – 1800 (U.S.) SPECIFICATIONS.....34
 APPENDIX A – 1800 (O.U.S.) SPECIFICATIONS36

IMPORTANT NOTICE

3M reserves the right to sell or furnish NEW OR RECONDITIONED PARTS.
 New and reconditioned parts are covered by the same 3M new parts limited warranty.

Illustrated Parts Breakdown (IPB)

This Illustrated Parts Breakdown (IPB) Manual contains the information necessary to locate and identify assemblies, sub-assemblies, and specific parts of the 1800 Overhead Projector.

Part Numbers

All components available on a replacement basis are listed with their 3M identification number. The parts identification list opposite each illustration provides the description adequate to identify components. If the component is available only as part of the next higher assembly, the description column provides the next higher assembly description or identification number.

Locating and Identifying a Part

If physical appearance and general location of an item are known:

1. Use the IPB Section Titles to help determine which assembly or sub-assembly includes the item.
2. Refer to the view for the assembly or sub-assembly and locate the item on the exploded view. Match the part callout number to the corresponding number in the parts list.
3. Parts shown inside a dashed box can only be ordered as an assembly. Any part or mounting hardware shown outside the box is not included with the assembly.

Machine Identification Plate

The serial number plate for the 1800 is located on the bottom panel of the projector. The Machine Identification Plate is divided into the following components:

1. **Product Name:** The specific version number of the projector.
2. **Model Number/Alpha Code:** The series number of the projector followed by a three or four character alpha code identifier. The Alpha Code indicates the design level, specific product characteristics, power cord or distribution specific to a country.
3. **Lamp:** The electrical rating of the lamp.
4. **MFG Code:** The MFG Code indicates the year and quarter the projector was built.
5. **S/N:** The serial number assigned to this projector.

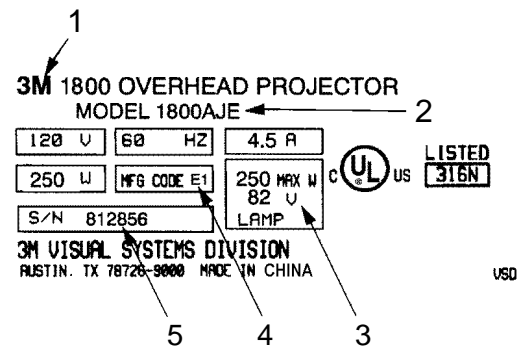

MFG Code			
Letter		Digit	
K	2001	1	Jan-Mar
L	2002	2	Apr-Jun
M	2003	3	Jul-Sep
A	2004	4	Oct-Dec
C	2005	1	Jan-Mar

Ordering Parts

When ordering parts, include the following information:

1. Machine model number and serial number.
2. Parts identification number.
3. Part description.
4. Quantity required.

For U.S. retail customers: Call 1-800-650-8429, or fax 1-800-650-9268. Dealers: Refer to Dealers Guide. 3M Subsidiaries: Contact Export Operations.

Quick Reference Parts Index

Description (By machine location)	Part Number	Section No.	Item No.
Inverted Singlet Head Module	78-8120-8508-8	1	1
Inverted Triplet Head Module	78-8120-8509-6	1	2
Inverted Mirror Module	78-8120-8498-2	1	3
Light Shield Kit	78-8120-4070-3	1	9
Open Singlet Head Module	78-8120-8507-0	2	1
Open Mirror Module	78-8120-8499-0	2	2
Closed Head Module, Singlet	78-8120-8506-2	3	1
Closed Head Module, Doublet	78-8120-8505-4	3	2
Arm Kit (Includes basic post)	78-8120-8575-7	4 & 5	1A
Arm/Offset Post Kit	78-8120-8576-5	4 & 5	1B
Post Pivot Kit	78-8120-8516-1	6	1
Post, Basic Arm	78-8120-8514-6	6	2
Offset Post Pivot Kit	78-8120-8515-3	6	3
Post, Inverted Arm	78-8120-8513-8	6	4
Top Cover Modules (U.S. and A4)	See Sections 7 & 8	7 & 8	1A – 1D
Fresnel Lens, Dual Element – 182.5 mm	78-8120-8504-7	7 & 8	6
Fresnel Lens, Dual Element (Inverted Singlet) – 175.3mm	78-8120-8502-1	7	6
On/Off Button Kit, Red	78-8120-8563-3	7 & 8	8A
On/Off Button Kit, Blue	78-8120-8564-1	7 & 8	8B
Base Mirror Module (EVD/FNT)	78-8120-8511-2	9	1
Base Mirror Module (ENX/FXL)	78-8120-8512-0	9	2
Base Module	78-8120-8517-9	9	8
Lamp Housing Kit	78-8120-8520-3	9	9
Transformers	See Section 9	9	4A – 4D
Power Cord, 120V (U.S. only)	78-8120-3184-3	9	11
ENX/FXL Single Lamp Socket	78-8120-3197-5	10	1
ENX/FXL Dual Lamp Socket	78-8120-3196-7	11	1
FNT Single Lamp Socket	78-8120-4003-4	12	8
FNT Dual Lamp Socket	78-8120-3193-4	13	4
EVD Dual Lamp Socket	78-8120-3193-4	14	4
Lamp, ENX	78-8011-1186-1	10 & 11	4A, 5A
Lamp, FXL	78-8073-7100-6	10 & 11	4B, 5B
Lamp, FNT	78-8054-1175-4	12 & 13	3, 5
Lamp, EVD	78-8079-8791-8	14	5
120V Fan Motor Assembly	XO-0038-1567-7	16	5
230V Fan Motor Assembly	XO-0038-1568-5	16	4
Roller Kit	See Section 17	17	1 – 4

Section 0. Machine Overview

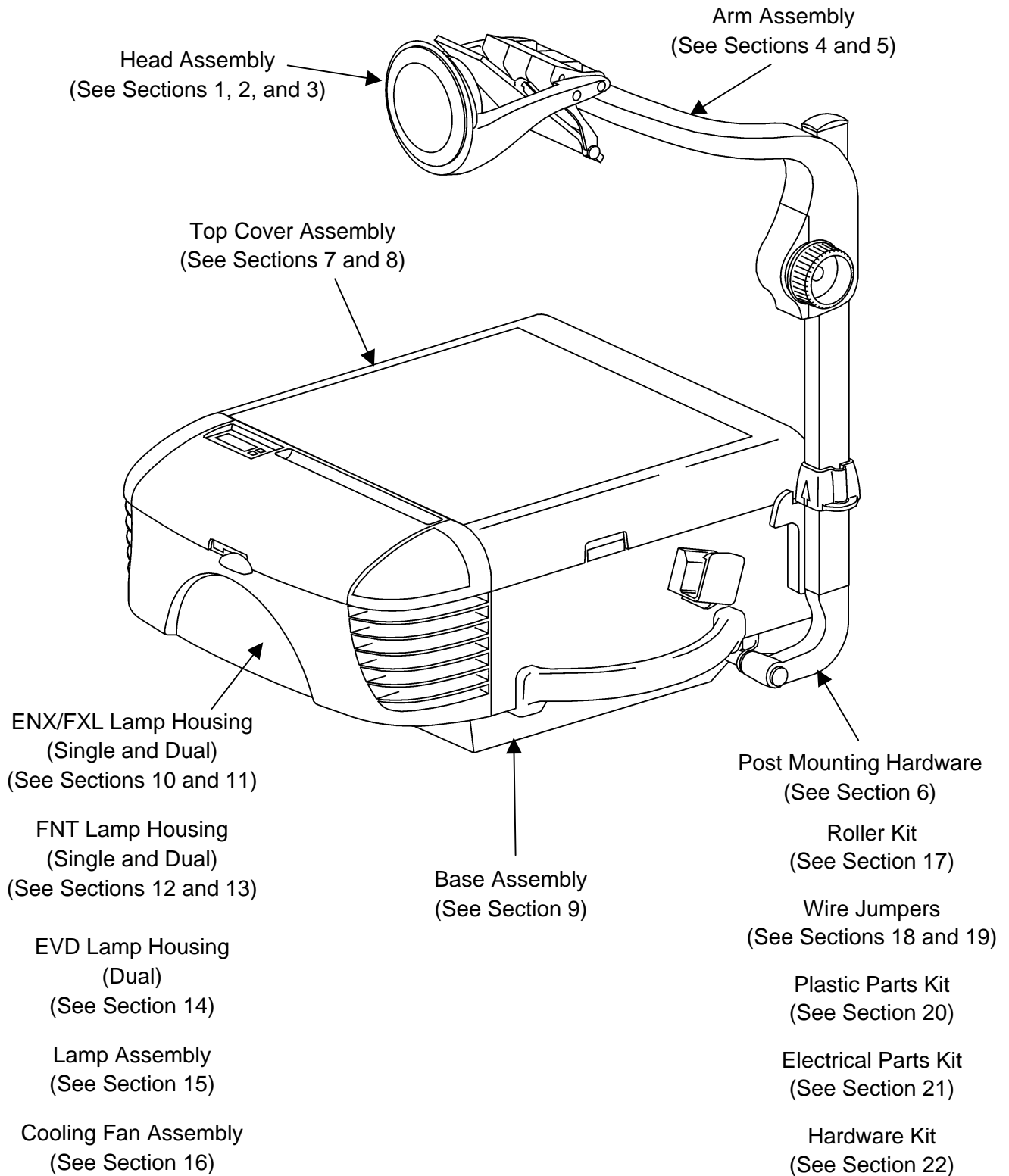

Section 1. Inverted Head Assembly

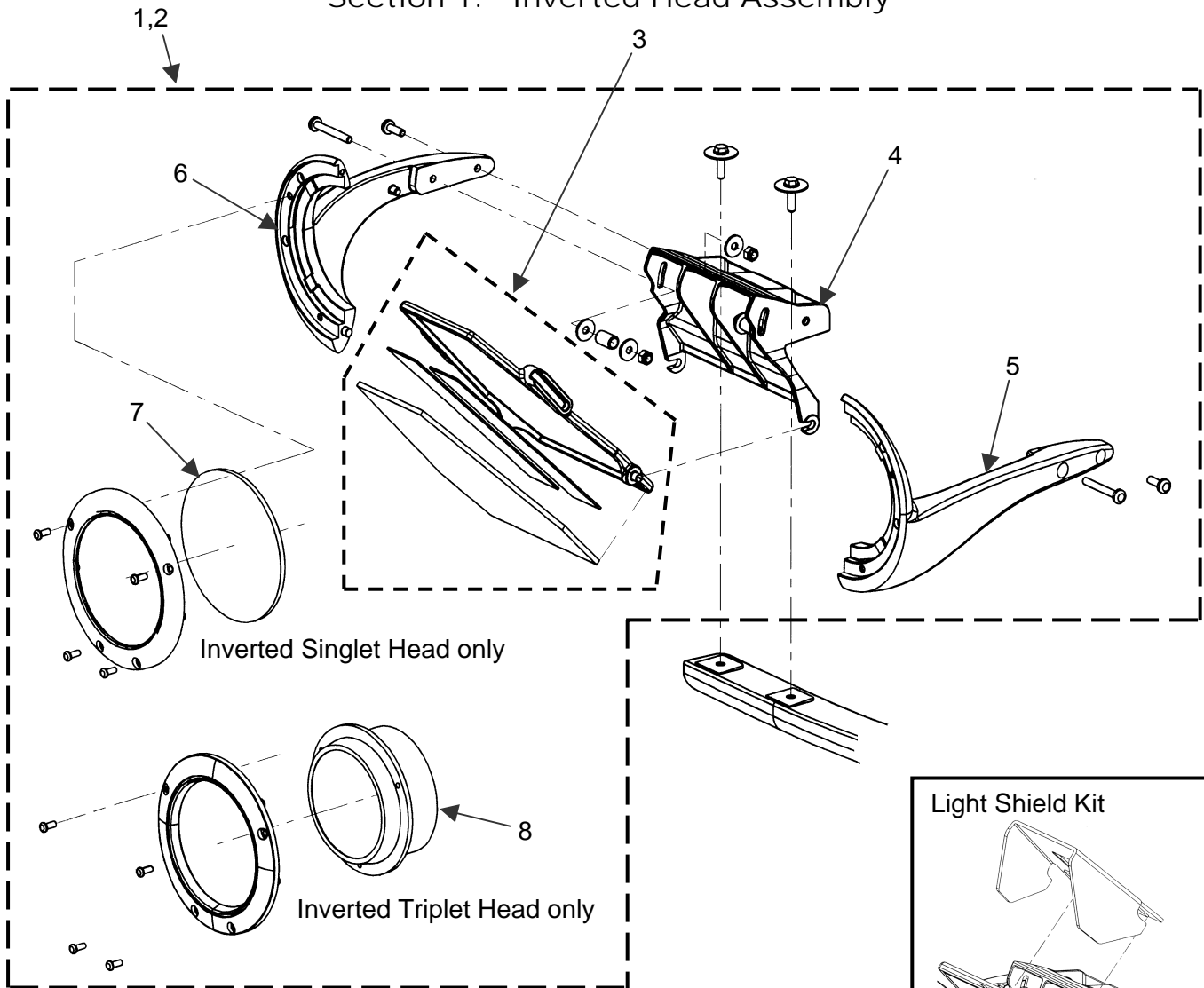

Note: Screws, nuts, bolts, clips, and other small hardware are also contained in the Hardware Kit: P/N 78-8120-8523-7 (Refer to Section 22).

Inverted Head Assembly Parts List

Item	3M Part Number	Description	Qty.
1	78-8120-8508-8	Inverted Singlet Head Module	1
2	78-8120-8509-6	Inverted Triplet Head Module	1
3	78-8120-8498-2	Inverted Mirror Module (Includes Mirror, Tape, and Holder)	1
4	78-8120-3158-7	Mount, Inverted Head	1
5	78-8120-3154-6	Yoke, Triplet, Left	1
6	78-8120-3155-3	Yoke, Triplet, Right	1
7	78-8096-5792-3	Lens, Wide Angle (254.78mm)	1
8	78-8097-3693-3	Lens, Triplet (345mm)	1
9	78-8120-4070-3	Light Shield Kit (Optional)	1

Section 2. Open Head Assembly

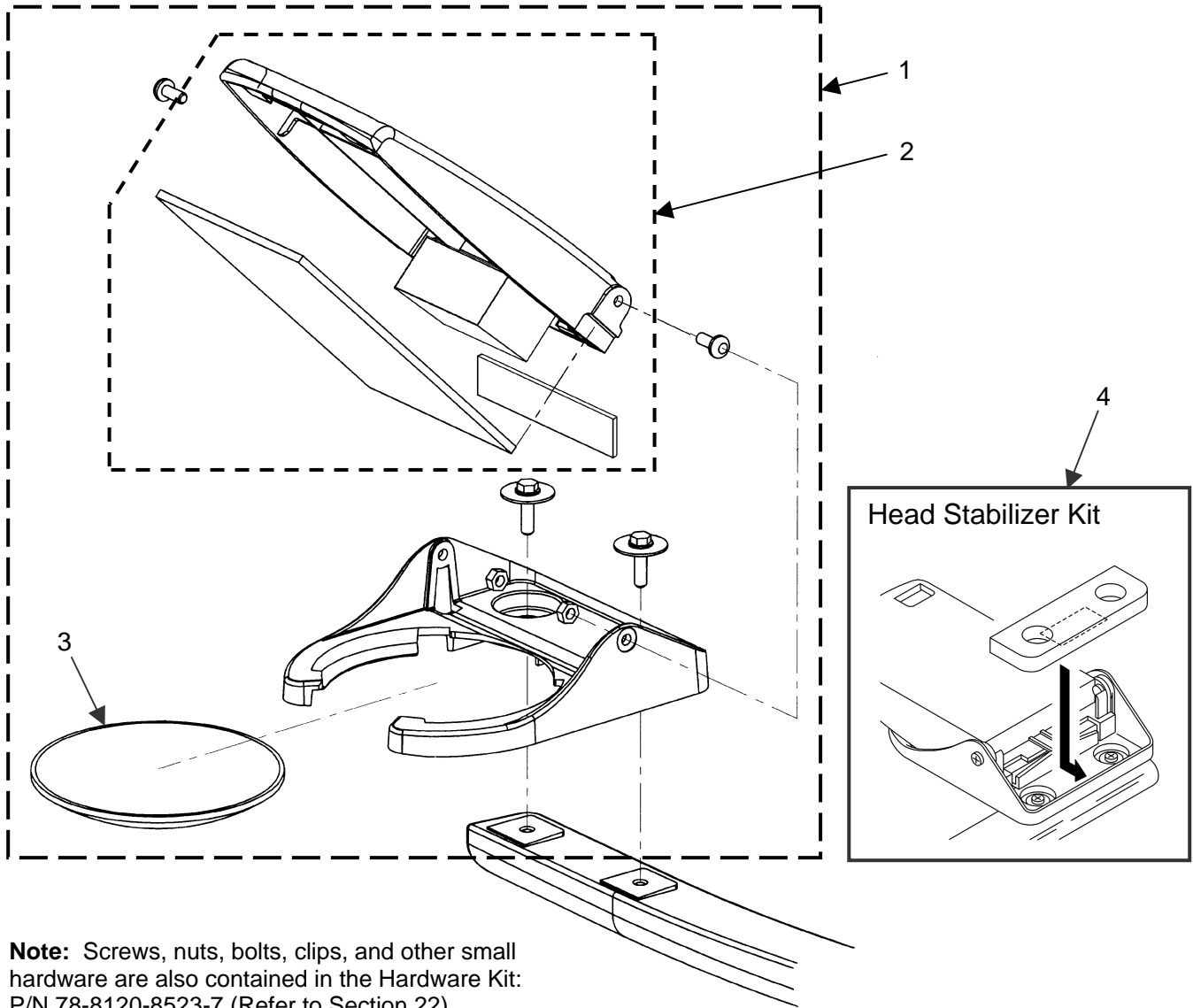

Note: Screws, nuts, bolts, clips, and other small hardware are also contained in the Hardware Kit: P/N 78-8120-8523-7 (Refer to Section 22).

Open Head Assembly Parts List

Item	3M Part Number	Description	Qty.
1	78-8120-8507-0	Open Singlet Head Module	1
2	78-8120-8499-0	Open Mirror Module	1
3	78-8014-8951-5	Lens, Wide Angle, Singlet (293mm)	1
4	78-8120-8565-8	Head Stabilizer Kit	1

Section 3. Closed Head Assembly

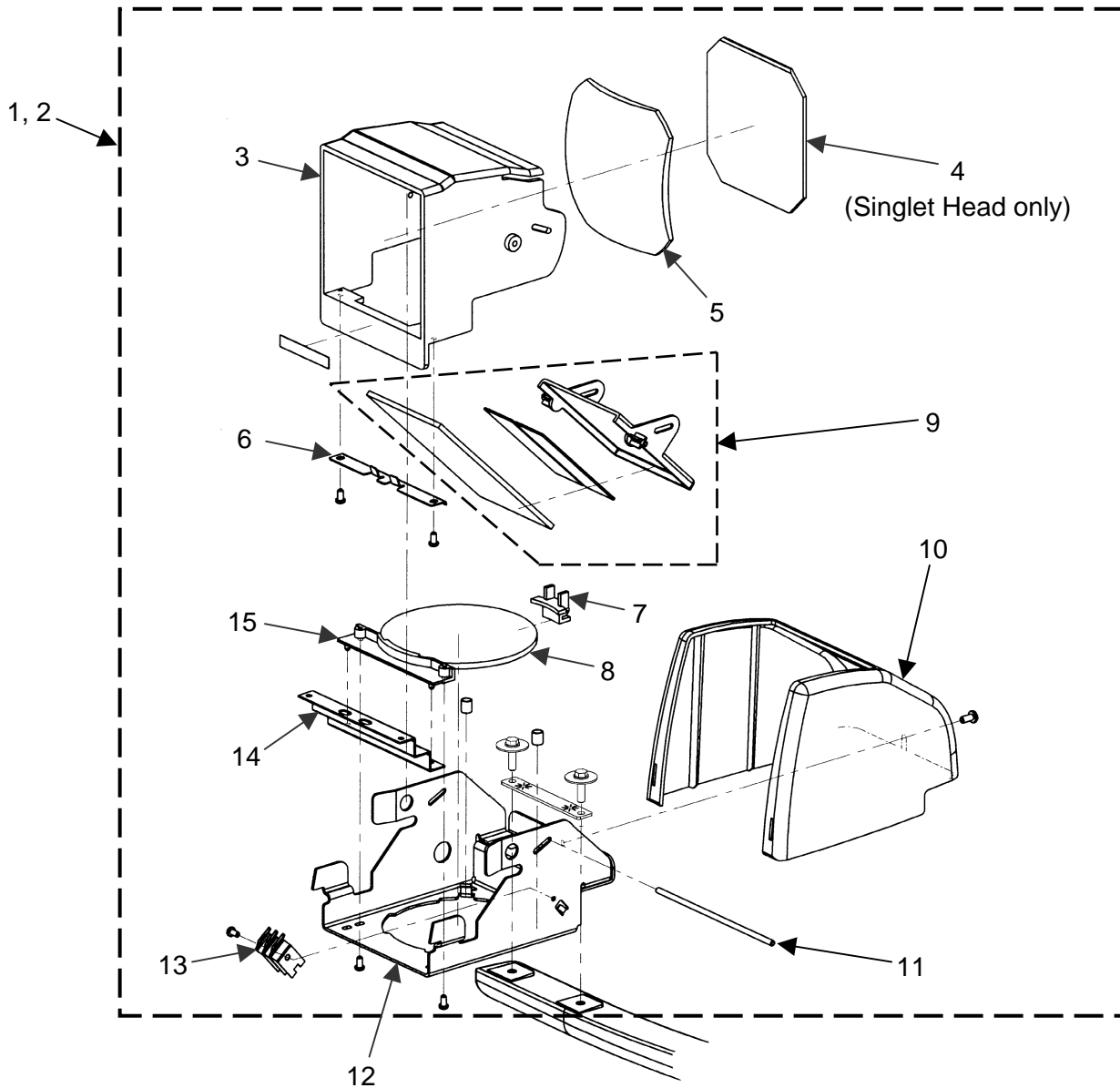

Note: Screws, nuts, bolts, clips, and other small hardware are also contained in the Hardware Kit: P/N 78-8120-8523-7 (Refer to Section 22).

Closed Head Assembly Parts List

Item	3M Part Number	Description	Qty.
1	78-8120-8506-2	Closed Head Module, Singlet (Includes Mirror Housing Assy.)	1
2	78-8120-8505-4	Closed Head Module, Doublet (Includes Mirror Housing Assy.)	1
3	78-8064-1562-2	Housing, Exit Lens	1
4	78-8073-2982-2	Glass, Articulate Head, Coated (Singlet only)	1
5	78-8014-8812-9	Lens, Articulate	1
6	78-8064-1602-6	Clamp, Dust Shield	1
7	78-8064-1643-0	Mount, Lens, Singlet	1
8A	78-8073-2980-6	Lens, Wide Angle (Singlet only)	1
8B	78-8011-1440-2	Lens, Meniscus (Doublet only)	1
9	78-8064-1457-5	Mirror Housing Assembly	1
10	78-8120-3122-3	Cover, Doublet, Articulate	1
11	78-8011-1445-1	Pivot, Rod	1
12	78-8120-3121-5	Bracket, Lens	1
13	78-8014-8817-8	Spring, Tension	1
14	78-8064-1797-4	Shield, Dust	1
15A	78-8064-1596-0	Clamp, Lens, Singlet (Singlet only)	1
15B	78-8064-1595-2	Clamp, Lens (Doublet only)	1
16	78-8054-1791-8	Clamp, Lens Dust Shield, Singlet (Not shown)	1
17	78-8064-1646-3	Tubing, Lens (Not shown)	1

Section 4. Arm Assembly
(Serial number 18040827 and below)

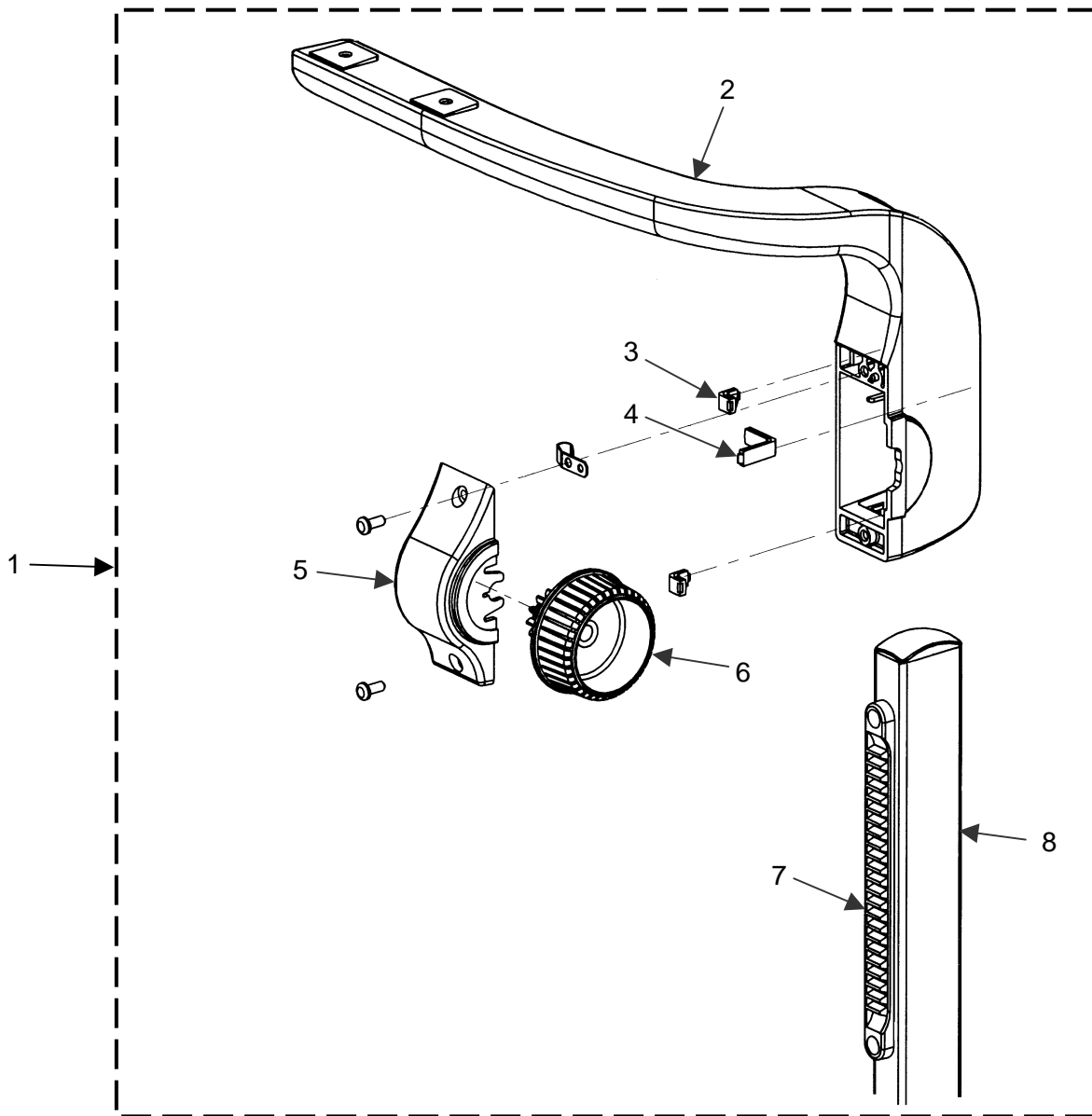

Note: Screws, nuts, bolts, clips, and other small hardware are also contained in the Hardware Kit: P/N 78-8120-8523-7 (Refer to Section 22).

**Arm Assembly Parts List
(Serial number 18040827 and below)**

Item	3M Part Number	Description	Qty.
1A	78-8120-8575-7	Arm Kit (includes basic post)	1
1B	78-8120-8576-5	Arm / Offset Post Kit	1
2	- - -	Arm, Focus (must order 78-8120-8575-7)	2
3	78-8120-4017-4	Pad, Tension	1
4	78-8120-3069-6	Pad	1
5	78-8120-3142-1	Cap, Focus	1
6	78-8120-3153-8	Knob, Focus Gear, Blue	1
7	78-8079-8744-7	Rack, Focus	1
8A	78-8120-8513-8	Post, Inverted Arm	1
8B	78-8120-8514-6	Post, Basic Arm	1
9	78-8120-8537-7	Arm / Post / with Inverted Singlet Head Assembly (Not shown)	1
10	78-8120-8539-3	Arm / Post With Inverted Triplet Head Assembly (Not shown)	1

Section 5. Arm Assembly
(Serial number 18040828 and above)

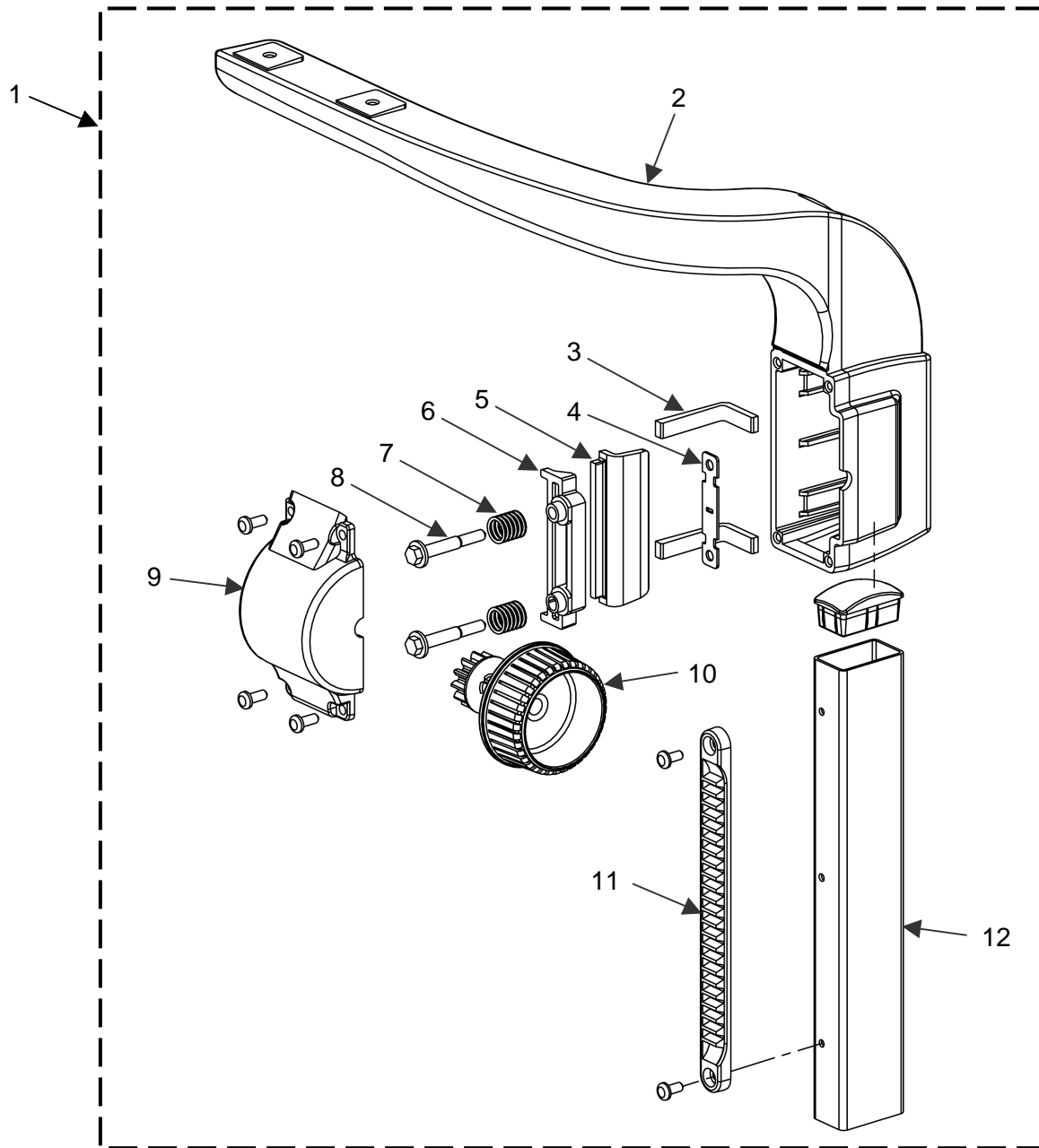

**Arm Assembly Parts List
(Serial number 18040828 and above)**

Item	3M Part Number	Description	Qty.
1A	78-8120-8575-7	Arm Kit (includes basic post)	1
1B	78-8120-8576-5	Arm / Offset Post Assembly Kit	1
2	- - -	Arm, Focus (must order 78-8120-8575-7)	2
3	See note	Pad, Insert	2
4	See note	Plate, Standoff	1
5	See note	Clamp, friction	1
6	See note	Pressure Bar	1
7	See note	Spring, Compression	2
8	See note	Screws, Shoulder	2
9	See note	Cap, Focus	1
10	RO-0038-1149-2	Knob, Focus Gear, Blue	1
11	78-8079-8744-7	Rack, Focus	1
12A	78-8120-8513-8	Post, Inverted Arm	1
12B	78-8120-8514-6	Post, Basic Arm	1
13	78-8120-8537-7	Arm / Post / Inverted Singlet Head Assembly (Not shown)	1
14	78-8120-8539-3	Arm Assembly, Inverted Triplet Head Assembly (Not shown)	1

NOTE: At the time of printing, this item is not available for purchase as an individual part.

Section 6. Post Mounting Hardware

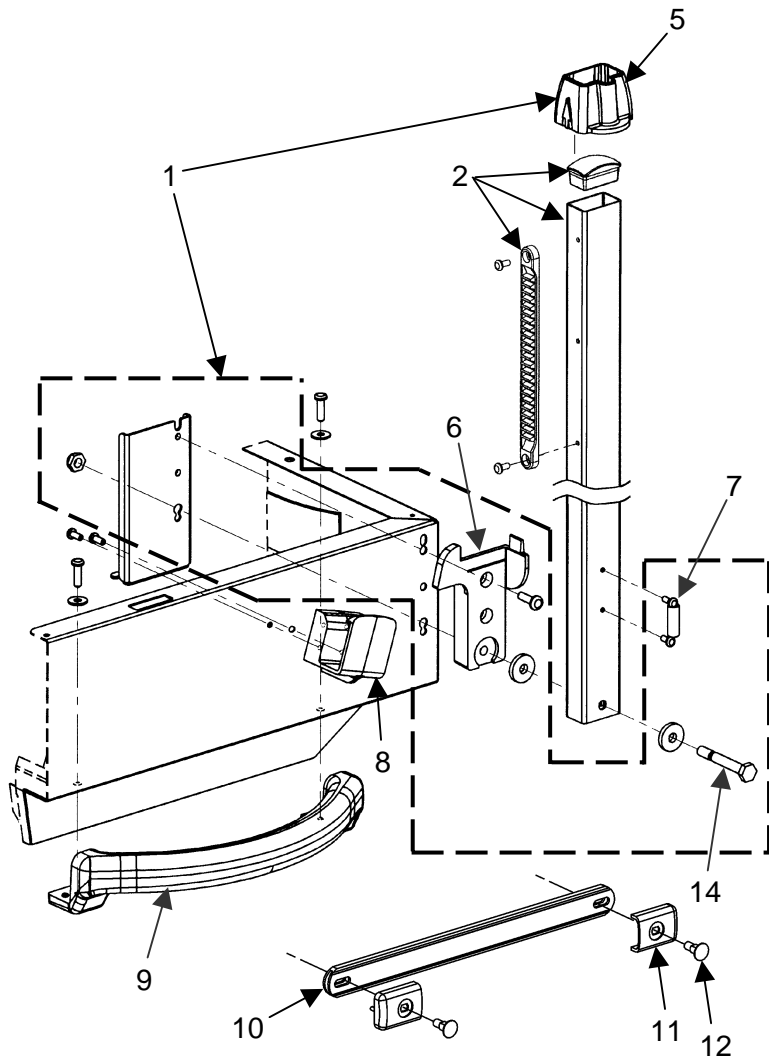

Basic (Post Mounting Hardware)

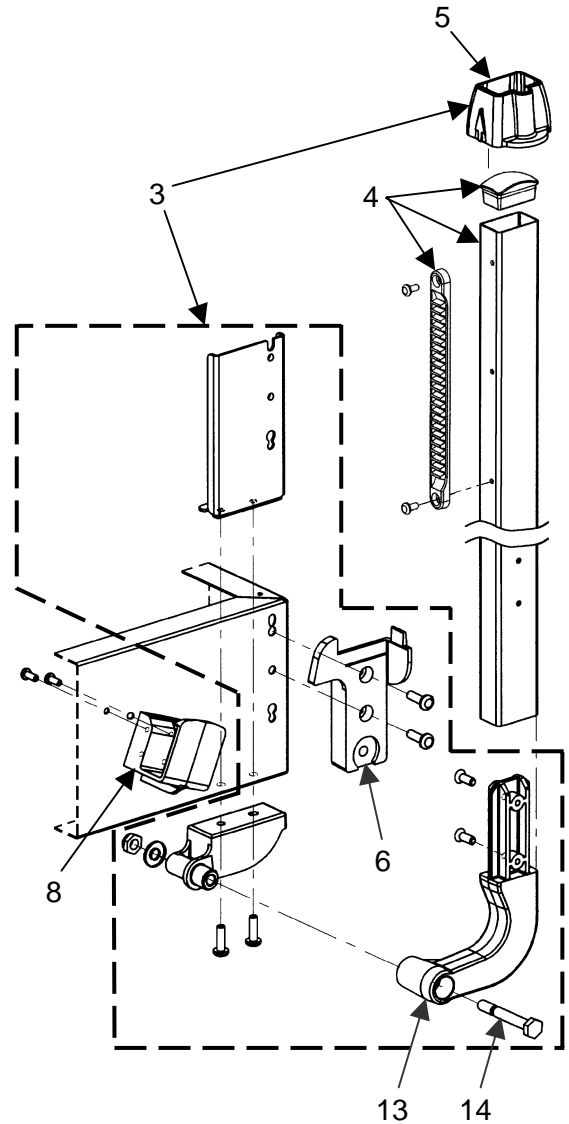

Inverted (Post Mounting Hardware)

Note: Screws, nuts, bolts, clips, and other small hardware are also contained in the Hardware Kit: P/N 78-8120-8523-7 (Refer to Section 22).

Post Mounting Parts List

Item	3M Part Number	Description	Qty.
1	78-8120-8516-1	Post Pivot Kit	1
2	78-8120-8514-6	Post, Basic Arm (includes focus rack and cap)	1
3	78-8120-8515-3	Offset Post Pivot Kit	1
4	78-8120-8513-8	Post, Inverted Arm (includes focus rack and cap)	1
5	78-8120-3108-2	Latch, Red	1
6	78-8120-3104-1	Block, Post Mount	1
7	78-8079-8997-1	Screw, Post Latch, Spring	1
8	78-8120-3144-7	Cradle, Post	1
9	78-8120-3126-4	Handle, Carry	1
10	78-8079-9218-1	Strap, Handle (Alternate)	1
11	78-8079-9217-3	Cap, End	2
12	---	Screw, End Cap	2
13	78-8120-4072-9	Pivot, Post, Offset	1
14	---	Bolt, Pivot	1

Section 7. Top Cover Assembly (with taped-in stage glass)

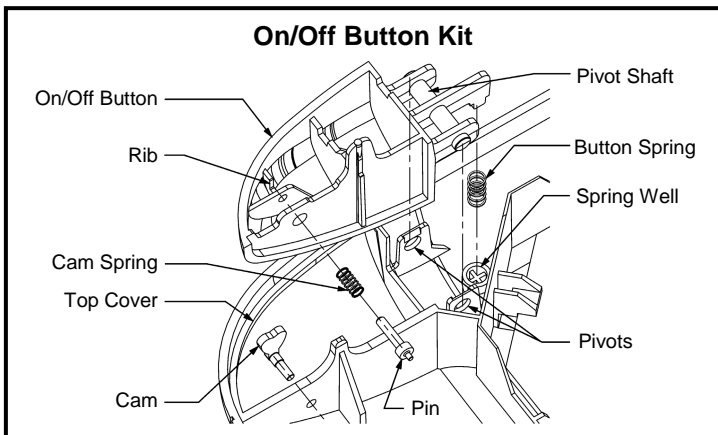
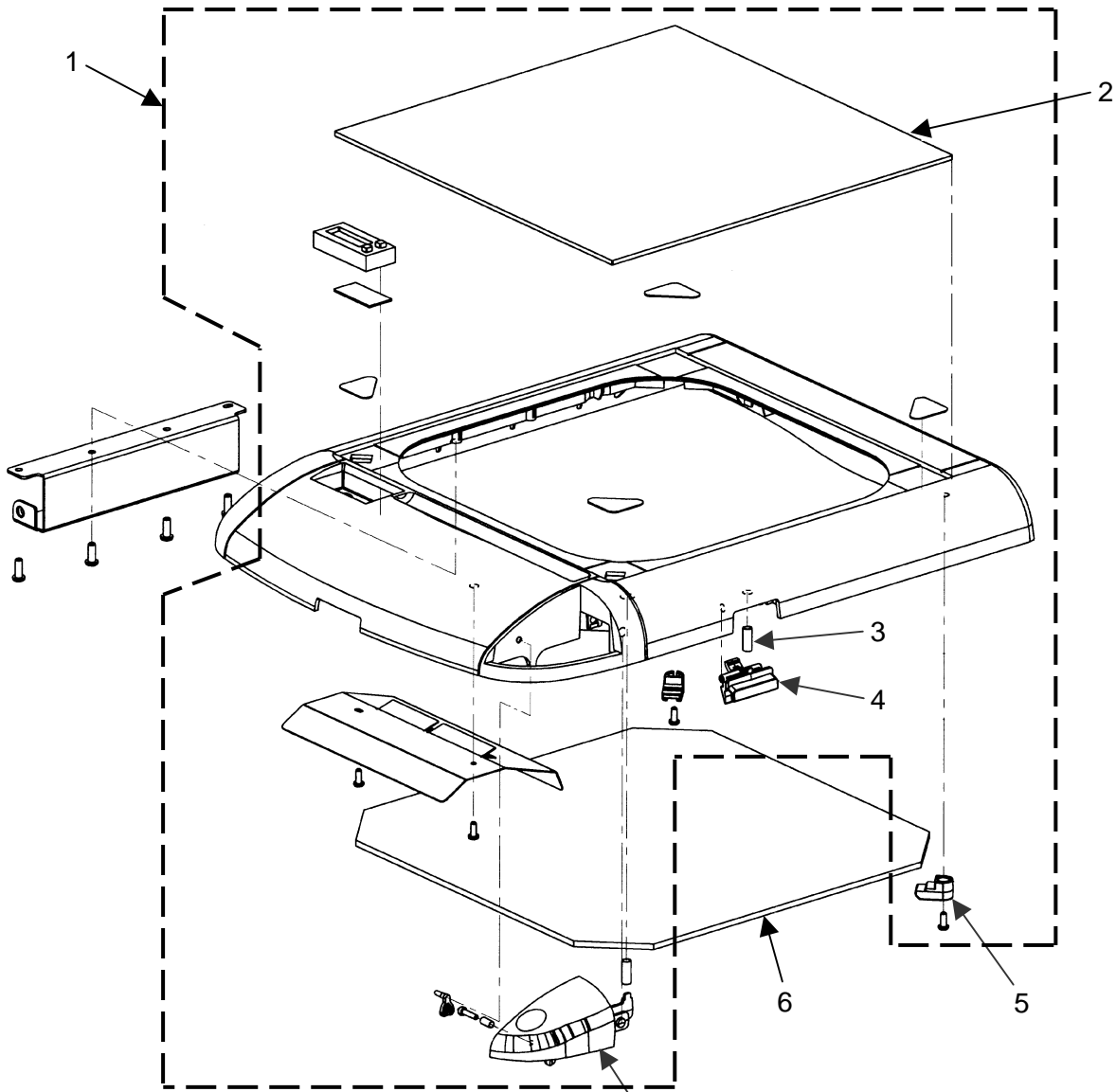

Note: Screws, nuts, bolts, clips, and other small hardware are also contained in the Hardware Kit: P/N 78-8120-8523-7 (Refer to Section 22).

Top Cover Assembly Parts List (with taped-in stage glass)

Item	3M Part Number	Description	Qty.
1A	78-8120-8570-8	Top Cover Module, Basic (U.S)	1
1B	78-8120-8571-6	Top Cover Module with Lamp Changer and Clock (U.S.)	1
1C	78-8120-8568-2	Top Cover Module, Basic (A4)	1
1D	78-8120-8569-0	Top Cover Module with Lamp Changer and Clock (A4)	1
2	78-8120-4155-2	Glass, Stage	1
3	78-8005-0481-9	Spring, Compression	1
4	78-8079-8768-6	Latch, Top Cover	1
5	78-8120-3114-0	Retainer, Fresnel	2
6A	78-8120-8502-1	Fresnel, Dual Element (inverted singlet) – 175.3 mm	1
6B	78-8120-8504-7	Fresnel, Dual Element – 182.5 mm	1
7A	78-8120-3138-9	Button, On/Off, Red	1
7B	78-8120-3151-2	Button, On/Off, Blue	1
8A	78-8120-8563-3	On/Off Button Kit, Red (Not shown)	1
8B	78-8120-8564-1	On/Off Button Kit, Blue (Not shown)	1

Note: Top covers prior to S/N 18023074 have taped-in stage glass. If the stage glass needs repair, a new top cover must be ordered. Refer to 1800 Technical Bulletin #6.

Section 8. Top Cover Assembly (with clipped-in stage glass)

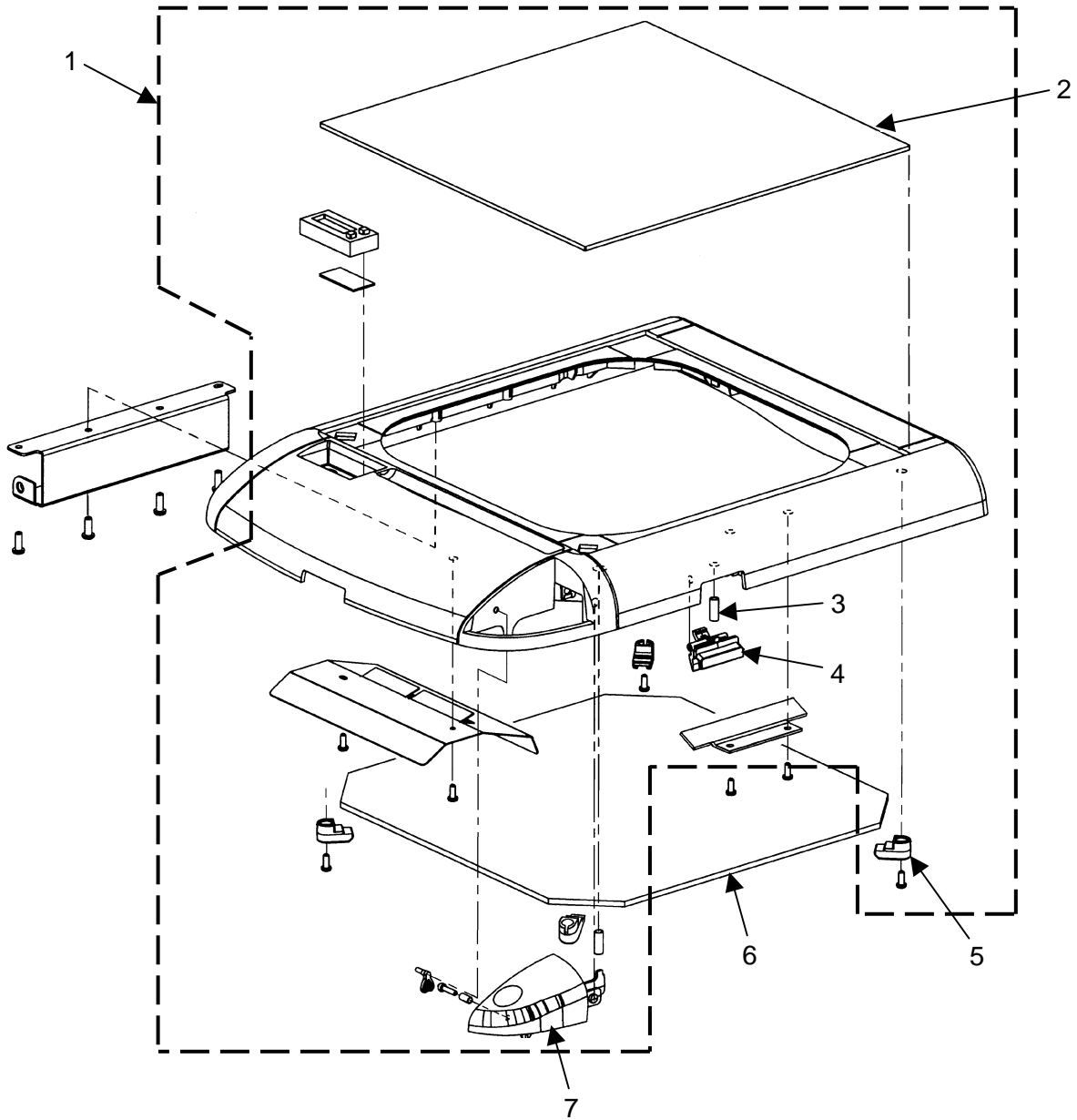

Note: Screws, nuts, bolts, clips, and other small hardware are also contained in the Hardware Kit: P/N 78-8120-8523-7 (Refer to Section 22).

Top Cover Assembly Parts List (with clipped-in stage glass)

Item	3M Part Number	Description	Qty.
1A	78-8120-8570-8	Top Cover Module, Basic (U.S)	1
1B	78-8120-8571-6	Top Cover Module with Lamp Changer and Clock (U.S.)	1
1C	78-8120-8568-2	Top Cover Module, Basic (A4)	1
1D	78-8120-8569-0	Top Cover Module with Lamp Changer and Clock (A4)	1
2	78-8120-4155-2	Glass, Stage	1
3	78-8005-0481-9	Spring, Compression	1
4	78-8079-8768-6	Latch, Top Cover	1
5	78-8120-3114-0	Retainer, Fresnel	4
6	78-8120-8504-7	Fresnel, Dual Element – 182.5 mm	1
7A	78-8120-3138-9	Button, On/Off, Red (See Section 7)	1
7B	78-8120-3151-2	Button, On/Off, Blue (See Section 7)	1
8A	78-8120-8563-3	On/Off Button Kit, Red (Not shown)	1
8B	78-8120-8564-1	On/Off Button Kit, Blue (Not shown)	1

Note: Top covers prior to S/N 18023074 have taped-in stage glass. If the stage glass needs repair, a new top cover must be ordered. Refer to 1800 Technical Bulletin #6.

Section 9. Base Assembly

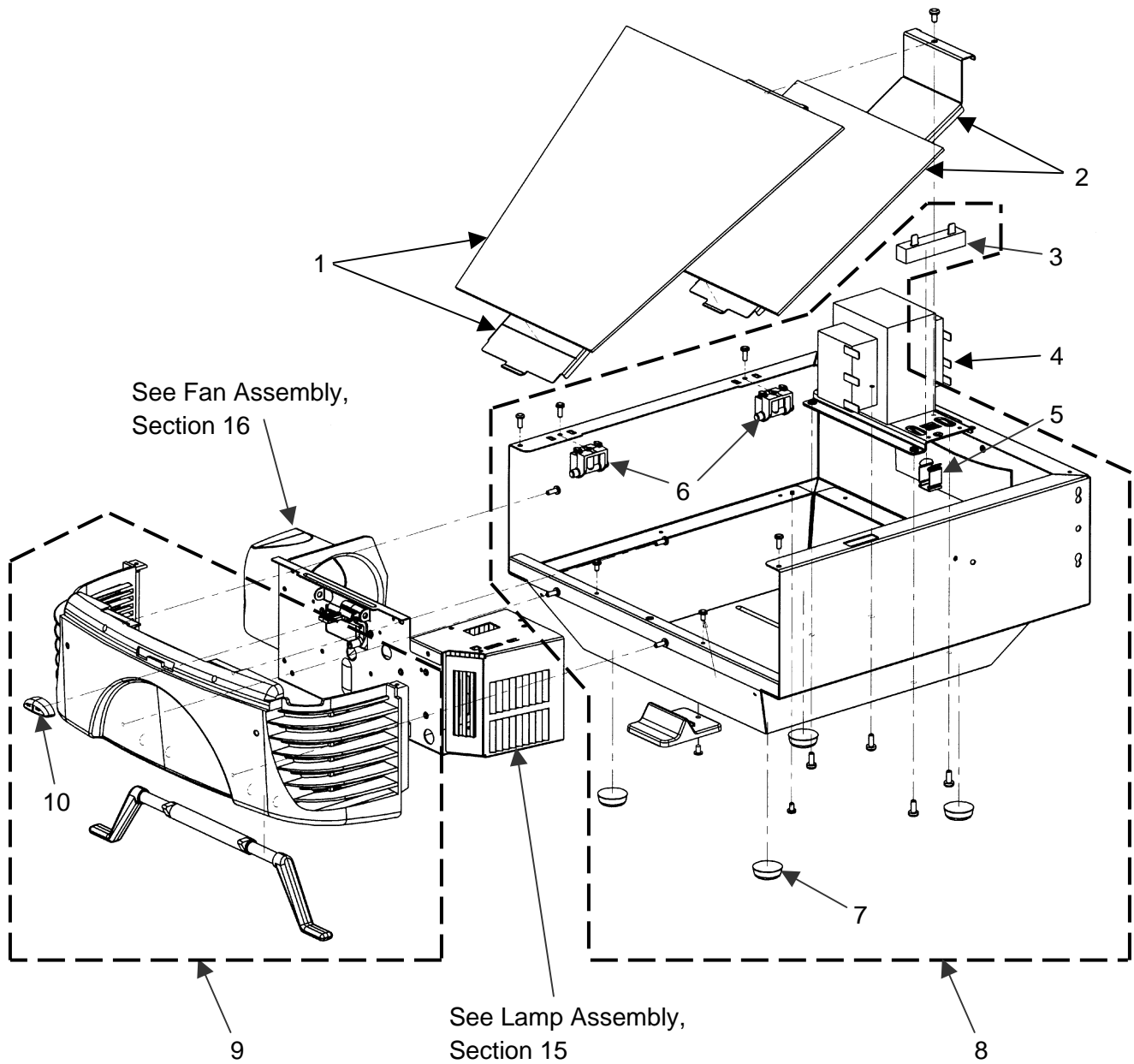

Note: Screws, nuts, bolts, clips, and other small hardware are also contained in the Hardware Kit: P/N 78-8120-8523-7 (Refer to Section 22).

Base Assembly Parts List

Item	3M Part Number	Description	Qty.
1	78-8120-8511-2	Base Mirror Module, EVD/FNT	1
2	78-8120-8512-0	Base Mirror Module, ENX/FXL	1
3	78-8073-7127-9	Resistor, 1.2 Ohm	1
4A	78-8120-3132-2	Transformer, EVD, 100-127V	1
4B	78-8120-3128-0	Transformer, EVD, 220-240V	1
4C	78-8120-3130-6	Transformer, FNT, 100-127V	1
4D	78-8120-3127-2	Transformer, FNT, 220-240V	1
5	78-8033-1666-6	Clip, Resistor	1
6	78-8120-3110-8	Pivot, Top Cover	2
7	(No charge)	Foot	4
8	78-8120-8517-9	Base Module	1
9	78-8120-8520-3	Lamp Housing Kit	1
10A	78-8120-3096-9	Knob, Lamp Changer, Red	1
10B	78-8120-3162-9	Knob, Lamp Changer, Blue	1
11	78-8120-3184-3	Power Cord, 120V (Not shown)	1

Section 10. Lamp Housing (Single ENX/FXL)

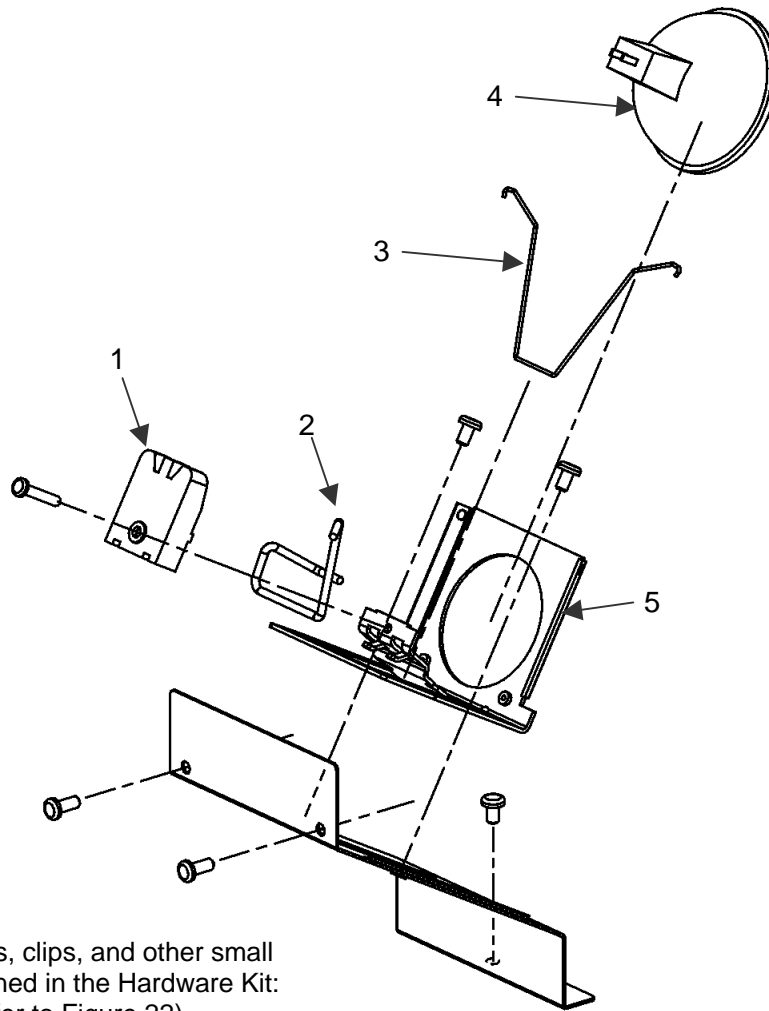

Note: Screws, nuts, bolts, clips, and other small hardware are also contained in the Hardware Kit: P/N 78-8120-8523-7 (Refer to Figure 22).

Lamp Housing (Single ENX/FXL) Parts List

Item	3M Part Number	Description	Qty.
1	78-8120-3197-5	Socket, Lamp, Single ENX/FXL	1
2	78-8064-1491-4	Ejector, Lamp	1
3	78-8064-1510-1	Spring, Lamp Retaining	1
4A	78-8011-1186-1	Lamp, ENX	1
4B	78-8073-7100-6	Lamp, FXL	1
5	78-8073-7208-7	Bracket, Socket	1

Section 11. Lamp Housing (Dual ENX/FXL)

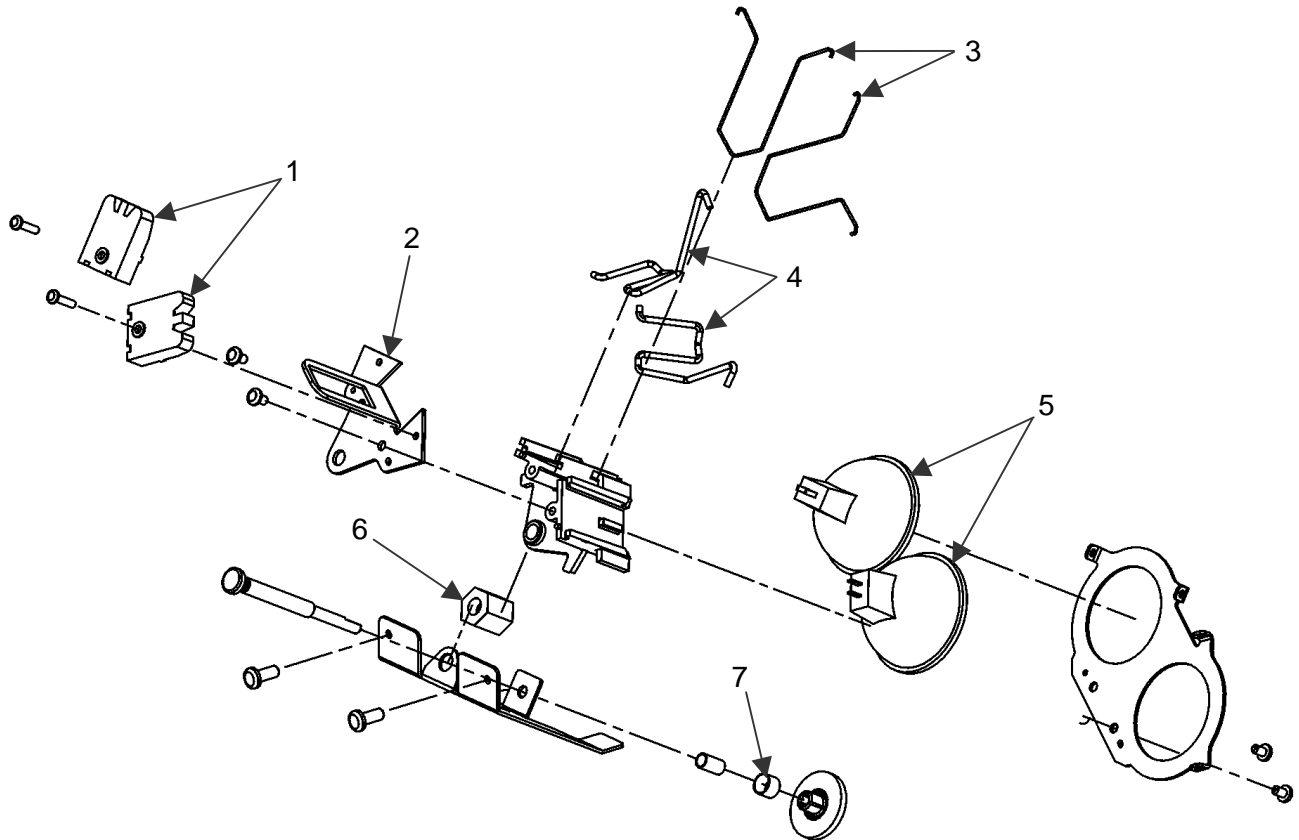

Note: Screws, nuts, bolts, clips, and other small hardware are also contained in the Hardware Kit: P/N 78-8120-8523-7 (Refer to Figure 22).

Lamp Housing (Dual ENX/FXL) Parts List

Item	3M Part Number	Description	Qty.
1	78-8120-3196-7	Socket, Lamp, Dual ENX/FXL	2
2	78-8120-3088-6	Plate, Socket, Dual ENX/FXL	1
3	78-8079-8863-5	Retainer, Lamp	2
4	78-8079-8862-7	Ejector, Lamp	2
5A	78-8011-1186-1	Lamp, ENX	2
5B	78-8073-7100-6	Lamp, FXL	2
6	78-8079-8866-8	Sleeve, Color Tune	1
7	26-1009-7186-5	Clip, Speed, Knob to Shaft	1

Section 12. Lamp Housing (Single FNT)

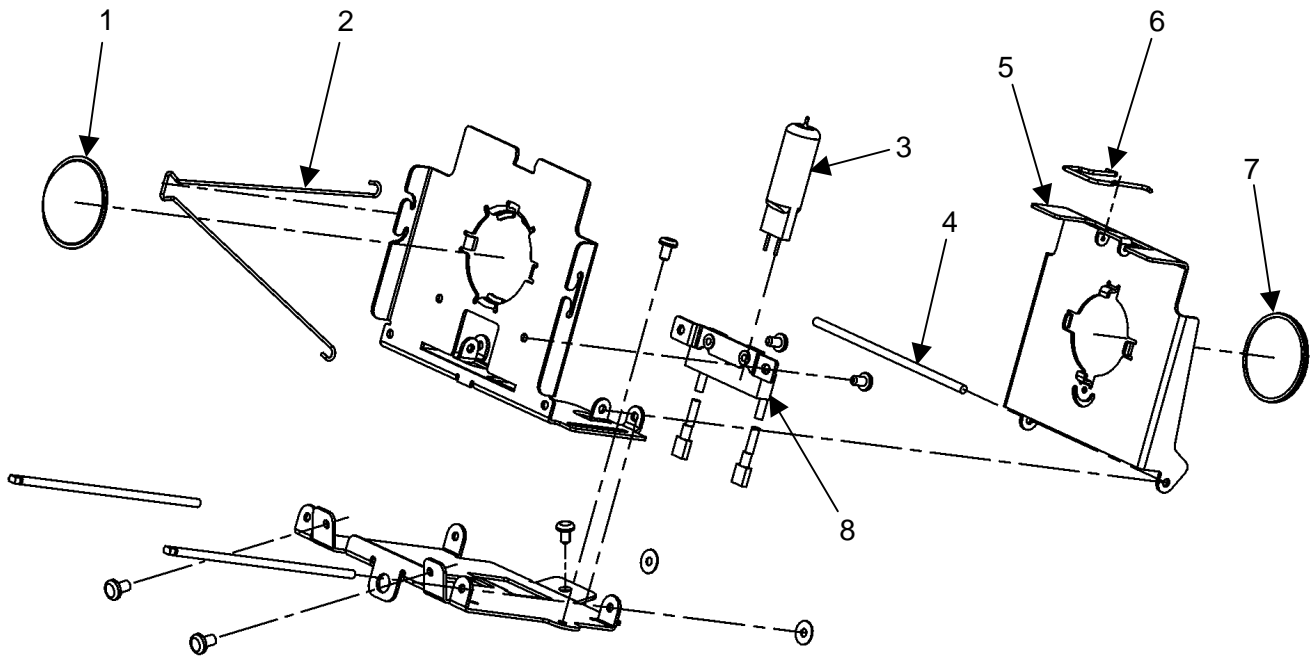

Note: Screws, nuts, bolts, clips, and other small hardware are also contained in the Hardware Kit: P/N 78-8120-8523-7 (Refer to Figure 22).

Lamp Housing (Single FNT) Parts List

Item	3M Part Number	Description	Qty.
1	78-8079-8829-6	Reflector, FNT	1
2	78-8079-8896-5	Spring, Reflector Retainer	1
3	78-8054-1175-4	Lamp, FNT	1
4	---	Rod, Center, EVD/FNT	1
5	78-8079-8834-6	Bracket, Small Condenser	1
6	78-8079-9053-2	Spring, Catch	1
7	78-8012-7827-2	Condenser, FNT	1
8	78-8120-4003-4	Socket, Single FNT	1

Section 13. Lamp Housing (Dual FNT)

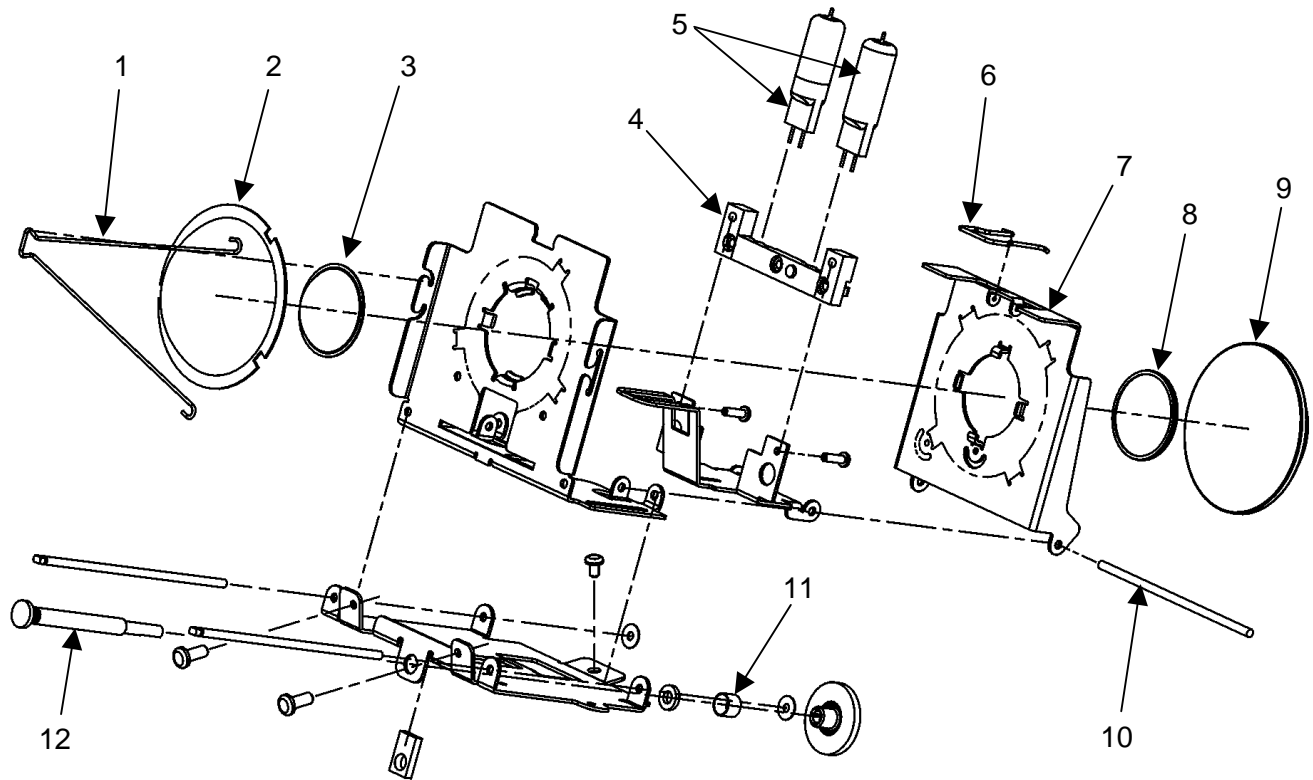

Lamp Housing (Dual FNT) Parts List

Item	3M Part Number	Description	Qty.
1	78-8079-8896-5	Spring, Reflector Retainer	1
2	78-8079-9202-5	Reflector. 60mm, FNT	1
3	78-8079-8829-6	Reflector, FNT	1
4	78-8120-3193-4	Socket, Lamp, Dual FNT	1
5	78-8054-1175-4	Lamp, FNT	2
6	78-8079-9053-2	Spring, Catch	1
7A	78-8079-8834-6	Bracket, Small Condenser	1
7B	78-8079-8836-1	Bracket, Large Condenser	1
8	78-8012-7827-2	Condenser, FNT	1
9	78-8079-9025-0	Condenser, Dual	1
10	---	Rod, Center, EVD/FNT	1
11	26-1009-7186-5	Clip, Speed, Knob to Shaft	1
12	78-8079-8928-6	Shaft, Color Tune, EVD/FNT	1

Section 14. Lamp Housing (Dual EVD)

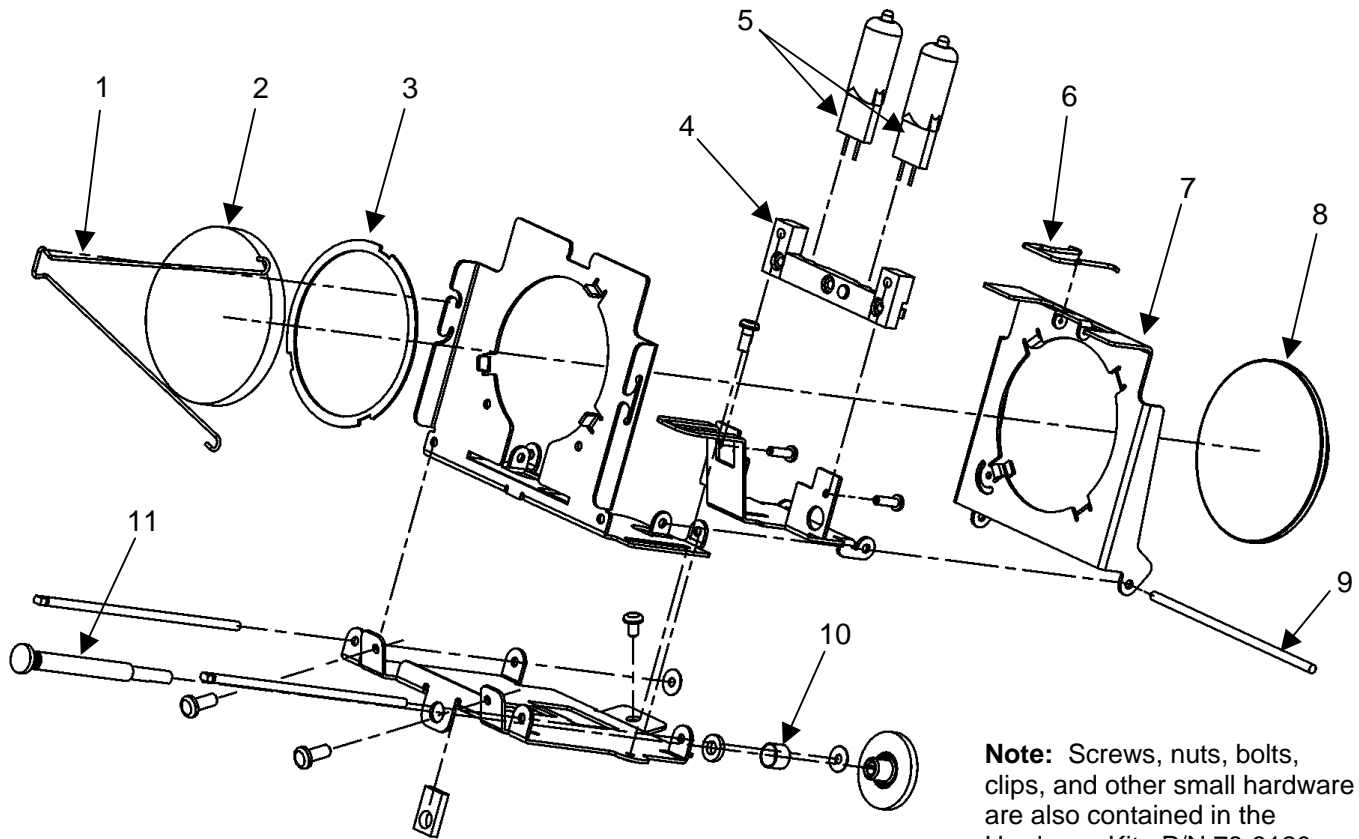

Note: Screws, nuts, bolts, clips, and other small hardware are also contained in the Hardware Kit: P/N 78-8120-8523-7 (Refer to Figure 22).

Lamp Housing (Dual EVD) Parts List

Item	3M Part Number	Description	Qty.
1	78-8079-8896-5	Spring, Reflector Retainer	1
2	78-8054-1775-1	Reflector, 60mm, EVD	1
3	78-8097-3649-5	Spacer, Reflector	1
4	78-8120-3193-4	Socket, Lamp, Dual	1
5	78-8079-8791-8	Lamp, EVD	2
6	78-8079-9053-2	Spring, Catch	1
7	78-8079-8836-1	Bracket, Large Condenser	1
8	78-8079-9025-0	Condenser, Dual EVD	1
9	---	Rod, Center, EVD/FNT	1
10	26-1009-7186-5	Clip, Speed, Knob to Shaft	1
11	78-8079-8928-6	Shaft, Color Tune, EVD/FNT	1

Section 15. Lamp Assembly

Note: Screws, nuts, bolts, clips, and other small hardware are also contained in the Hardware Kit: P/N 78-8120-8523-7 (Refer to Figure 22).

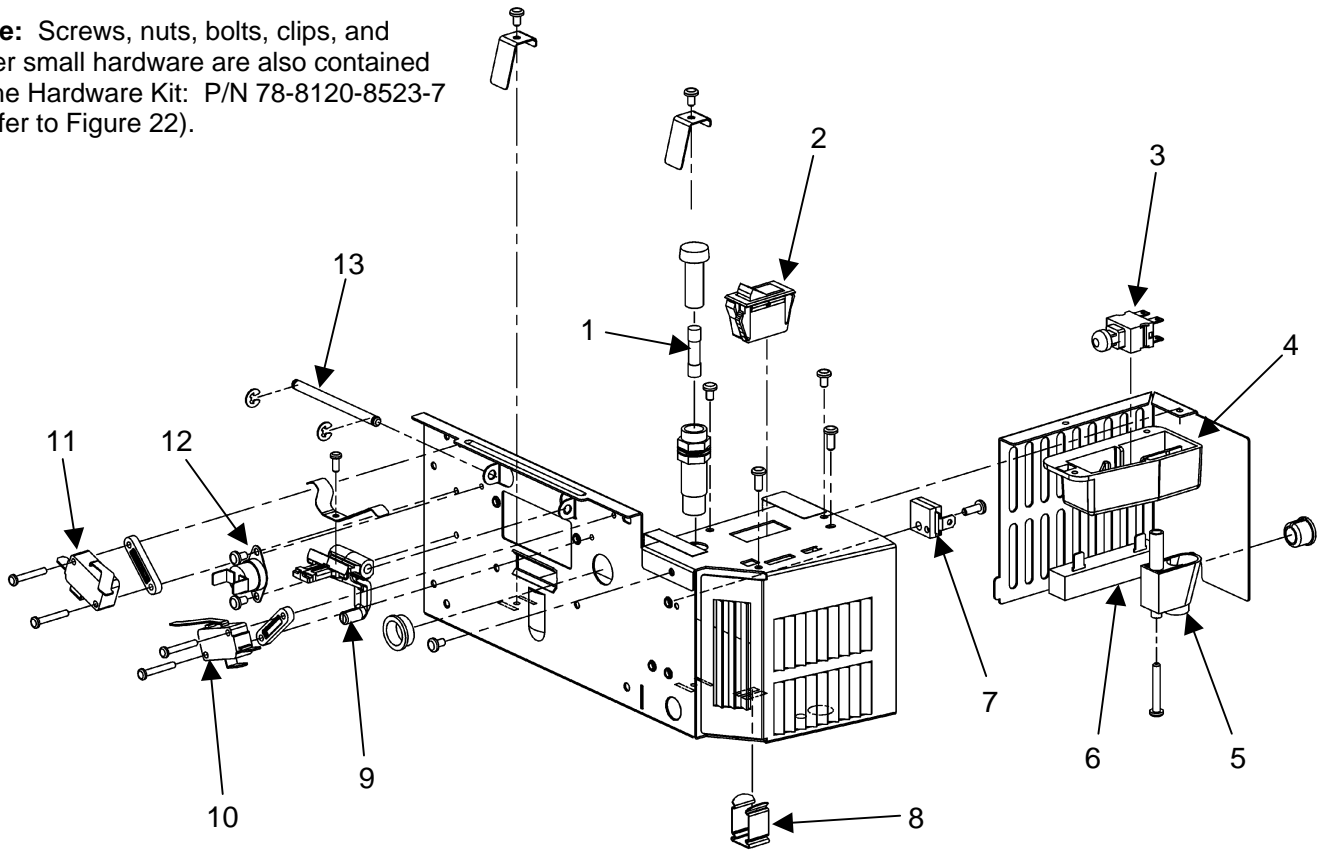

Lamp Assembly Parts List

Item	3M Part Number	Description	Qty.
1A	26-1008-6347-6	Fuse, 4A	1
1B	26-1005-9599-5	Fuse, 5A	1
2	78-8073-7212-9	Switch, Hi/Lo	1
3	78-8120-3134-8	Switch, On/Off	1
4	78-8120-3134-8	Housing, On/Off Switch	1
5	DY-1160-2020-6	Strain Relief	1
6	78-8073-7127-9	Resistor, 1.2 Ohm	1
7	---	Diode <i>[Must order Diode Kit, P/N 78-8062-1180-7]</i>	1
8	78-8033-1666-6	Clip, Resistor	1
9	78-8120-3097-7	Actuator, Lamp Changer	1
10	78-8120-3079-5	Switch, Lamp Changer, Right Holder	1
11	78-8120-3080-3	Switch, Lamp Changer, Left Holder	1
12	78-8079-8933-6	Thermostat, Safety (190° F)	1
13	78-8120-3147-0	Shaft, Pivot Actuator	1

Section 16. Cooling Fan Assembly

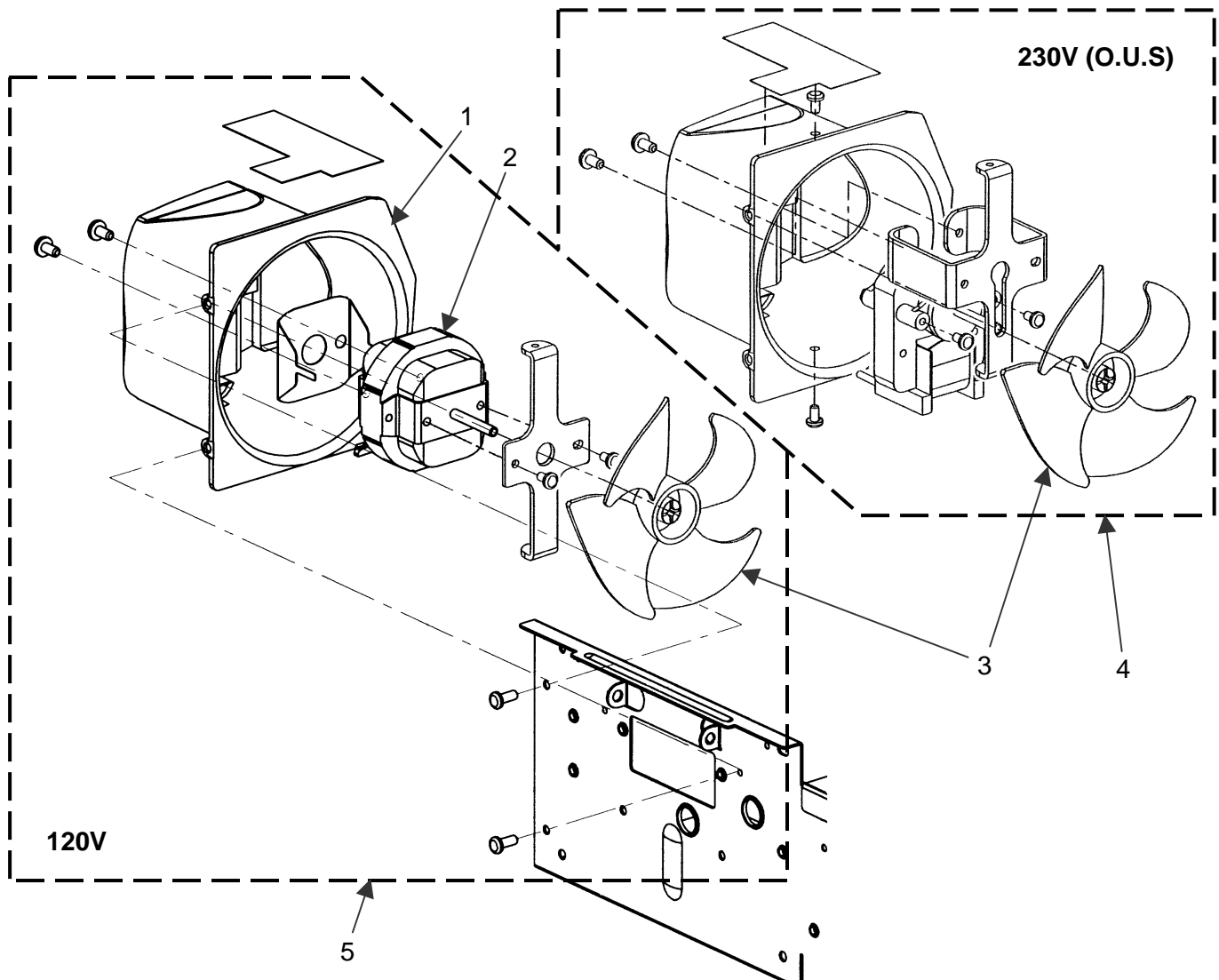

Note: Screws, nuts, bolts, clips, and other small hardware are also contained in the Hardware Kit: P/N 78-8120-8523-7 (Refer to Figure 22).

Cooling Fan Assembly Parts List

Item	3M Part Number	Description	Qty.
1	---	Duct, Fan	1
2	---	Motor, Fan, 120V	1
3	---	Blade, Fan	1
4	XO-0038-1568-5	Fan Motor Assembly, 230V	1
5	XO-0038-1567-7	Fan Motor Assembly, 120V	1

Section 17. Roll Film Kit

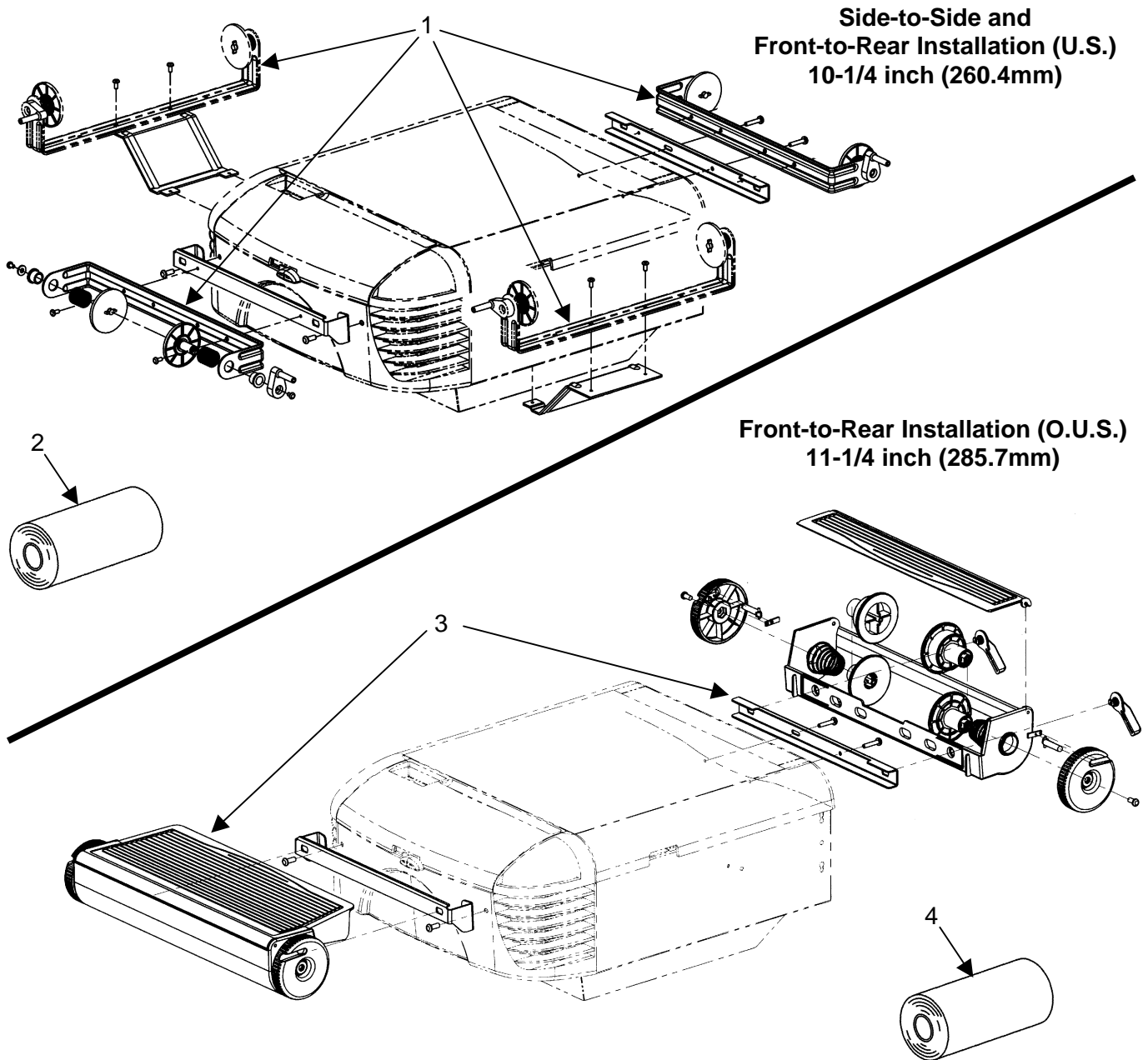

Roll Film Kit Parts List

Item	3M Part Number	Description	Qty.
1	XO-00380750-0	Kit, Roll Film, 10-1/4 in. (260.4mm) (Complete assembly)	1
2	XO-0038-0751-8	Film, Roll, 10-1/4 in. (260.4mm)	1
3	XO-0038-0504-1	Kit, Roll Film (A4), 11-1/4 in. (285.7mm) (Complete assembly)	1
4	78-6969-1751-3	Film, Roll (A4), 11-1/4 in. (285.7mm)	1

Section 18. Wire Jumpers (ENX and FXL)

ENX 1810, 1820, 1830, 1850

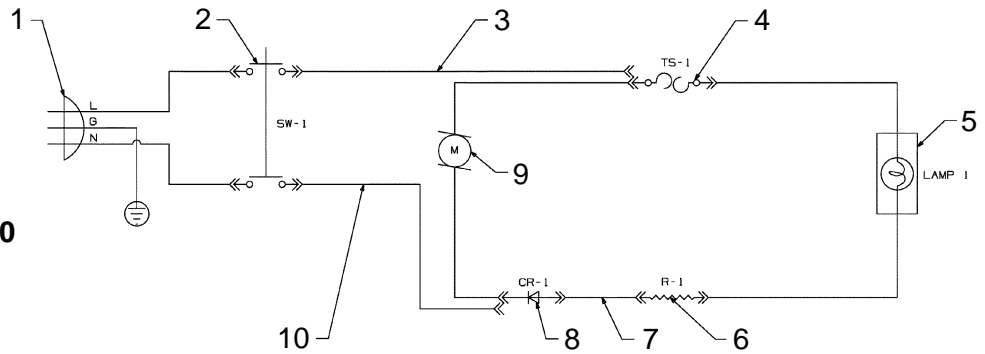

FXL 1825

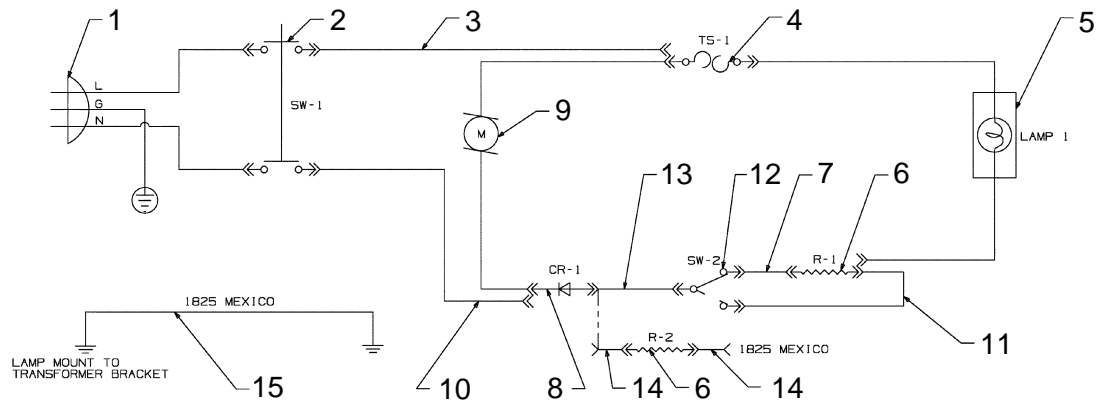

ENX 1840, 1860, 1870

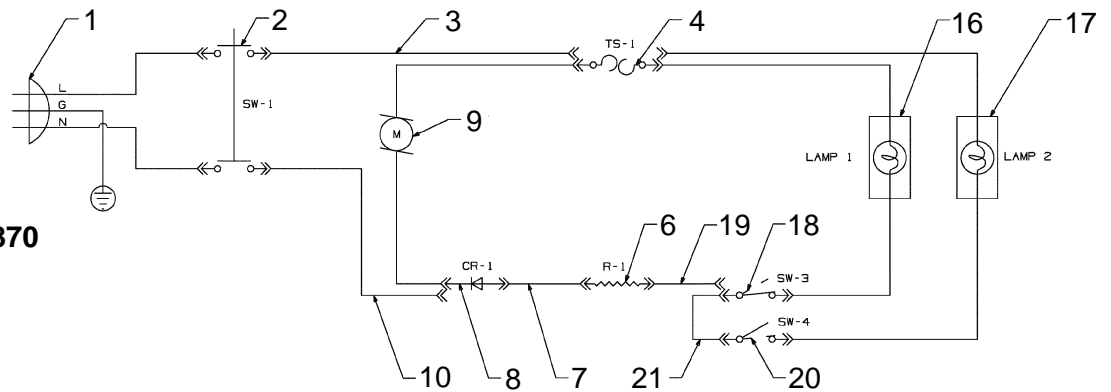

ENX 1880
FXL 1865, 1885, 1895

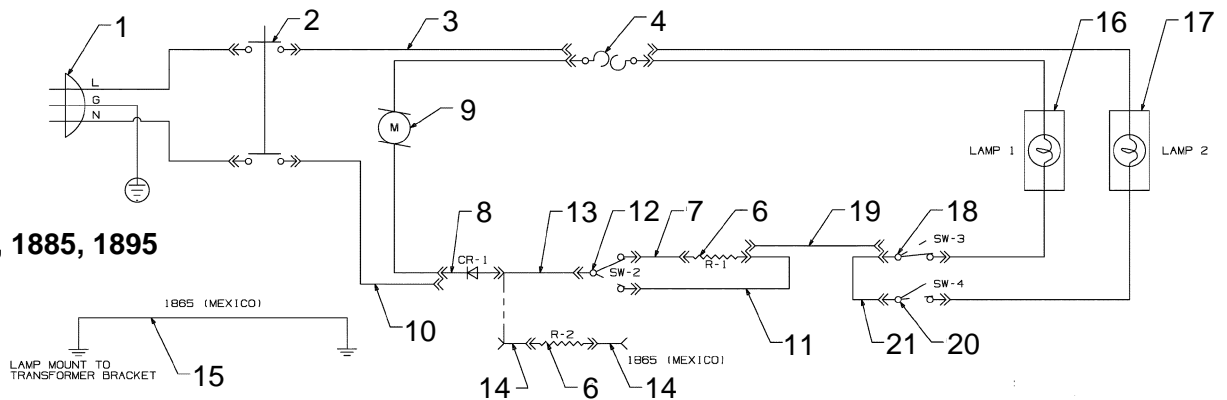

Wire Jumpers Parts List (ENX and FXL)

Item	3M Part Number	Description	Qty.
1	78-8120-3184-3	Power Cord, 120V	1
2	78-8120-3134-8	Switch, On/Off	1
3	---	Jumper, 14.5"	1
4	78-8079-8933-6	Thermostat, Safety (190° F)	1
5	78-8120-3197-5	Socket, Lamp, Single ENX / FXL	1
6	78-8073-7127-9	Resistor, 1.2 Ohm	1
7	---	Jumper, 4.5"	1
8	---	Diode [Must order diode kit 78-8062-1180-7]	1
9	XO-0038-1567-7	Fan Motor Assembly, 120V	1
10	---	Jumper, 5.5"	1
11	---	Jumper, 4"	1
12	78-8073-7212-9	Switch, Hi/Lo	1
13	---	Jumper, 3"	1
14	---	Jumper, 16"	1
15	---	Ground Wire to Transformer	1
16	78-8120-3196-7	Socket, Lamp, Dual ENX / FXL	1
17	78-8120-3197-5	Socket, Lamp, Single ENX / FXL	1
18	78-8120-3079-5	Switch, Lamp Changer, Right	1
19	---	Jumper, 7.5"	1
20	78-8120-3080-3	Switch, Lamp Changer, Left	1
21	---	Jumper, 13.5"	1

Section 19. Wire Jumpers (EVD and FNT)

FNT 1805

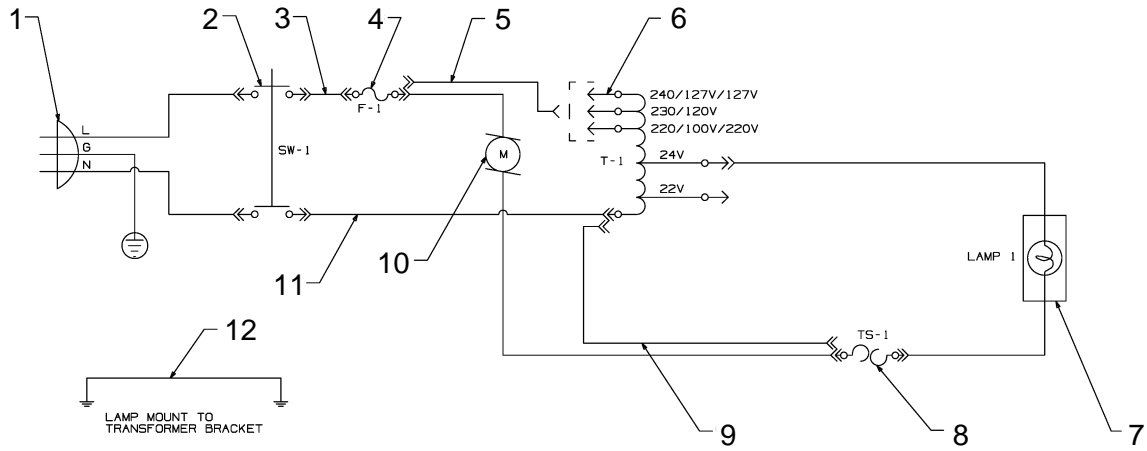

EVD and FNT

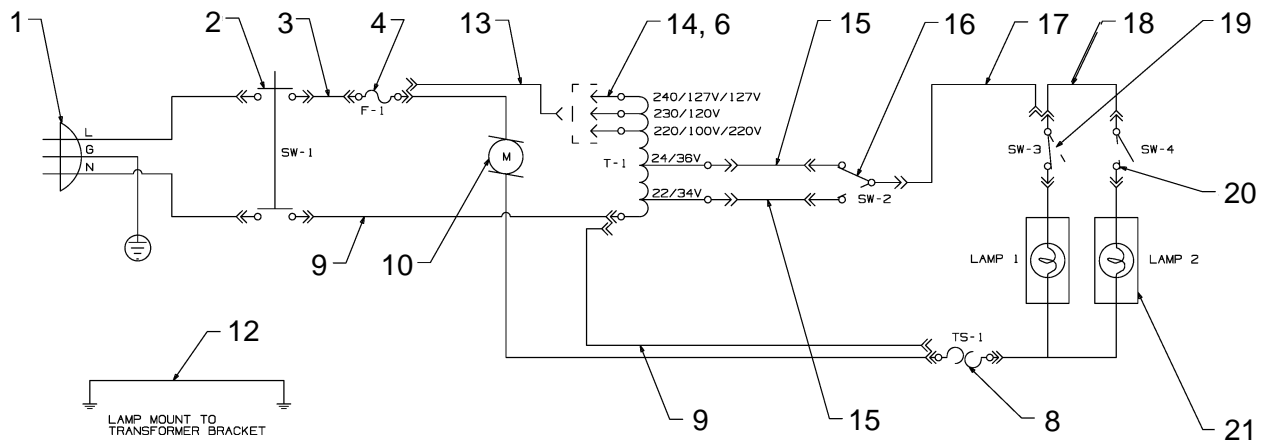

Wire Jumpers Parts List (EVD and FNT)

Item	3M Part Number	Description	Qty.
1	78-8120-3184-3	Power Cord, 120V	1
2	78-8120-3134-8	Switch, On/Off	1
3	---	Jumper, 6"	1
4A	26-1008-6347-6	Fuse, 4 Amp	1
4B	26-1005-9599-5	Fuse, 5 Amp, 5 x 20mm, Slow Acting	1
5	---	Jumper, 7.5"	1
6A	78-8120-3130-6	Transformer, FNT (100-127V)	1
6B	78-8120-3127-2	Transformer, FNT (220-240V)	1
7	78-8120-4003-4	Socket, Lamp, Single FNT	1
8	78-8079-8933-6	Thermostat, Safety (190° F)	1
9	---	Jumper, 22"	1
10A	XO-0038-1567-7	Fan Motor Assembly, 120V	1
10B	XO-0038-1568-5	Fan Motor Assembly, 230V	1
11	---	Jumper, 15"	1
12	---	Ground Wire to Transformer	1
13	---	Jumper, 7.5"	1
14A	78-8120-3132-2	Transformer, EVD (100-127V)	1
14B	78-8120-3128-0	Transformer, EVD (220-240V)	1
15	---	Jumper, 16"	1
16	78-8073-7212-9	Switch, Hi/Lo	1
17	---	Jumper, 7.5"	1
18	---	Jumper, 13.5"	1
19	78-8120-3079-5	Switch, Lamp Changer, Right Hand	1
20	78-8120-3080-3	Switch, Lamp Changer, Left Hand	1
21	78-8120-3193-4	Socket, Lamp, Dual EVD/FNT	1

Section 20. Plastic Parts Kit

3M Part Number	Description of Parts Included in Kit	Qty.
Plastic Parts Kit 78-8120-8521-1	Latch, Top Cover	2
	Spring, Compression, #LC-029C-5MW, 18.5 lb/in	1
	Spring, #LC-014B-4NW	2
	Strain Relief	1
	Fan	1
	Knob, Gear/Focus, Red	2
	Knob, Gear/Focus, Blue	2
	Latch, Folding Post, Red	2
	Latch, Folding Post, Blue	2
	Cradle, Post	3
	Pivot, Top Cover	2
	Button, On/Off, Red	1
	Button, On/Off, Blue	1
	Cam, Switch	2
	Pin, Cam Pivot	2
	Knob, Color Tune (Dual)	1
	Knob, Lamp Change, Red	3
	Knob, Lamp Change, Blue	3
	Cap, Post, Black	3
	Bar, Stabilizer	1

Section 21. Small Electrical Parts Kit

3M Part Number	Description of Parts Included in Kit	Qty.
Small Electrical Parts Kit 78-8120-8522-9	Clock, LCD	1
	Tape, Foam	1
	Resistor, 1.2 Ohm, 0.25 tab	3
	Clip, Tinnerman #C54923-017-4	1
	Switch, Lamp Changer, Left Hand	3
	Switch, Lamp Changer, Right Hand	3
	Thermostat	3
	Switch, Hi/Lo	3
	Fuse, 5 Amp, 5 x 20mm, Slow Acting	1
	Switch, Interlock	3
	Diode	5
	Socket, Lamp, Single	1
	Socket, lamp, ENX/FXL	1
	Socket, Lamp, Dual	1
	Socket, Lamp, Single FNT	1
	Dual Lamp Socket Assembly	1

Section 22. Hardware Kit

Hardware Kit 78-8120-8523-7			
Description of Parts Included in Kit	Qty.	Description of Parts Included in Kit	Qty.
Screw, Plastite, 4-20 x 1/4, Bzn	4	Bushing, 0.50 Mounting Hole Dia.	1
Screw, Taptite, Pan Head, M3.5 x 8, Bzn	8	Washer, Plain, #8	6
Screw, Plastite, 6-19 x 5/16 Long, Zinc	6	Screw, Plastite, 8-16 x 3/8 Long, Bzn	4
Screw, Taptite, M3 x 12, Zinc	2	Screw, Plastite, 4-20 x 3/8 Long, Bzn	5
Spring, Tension	3	Washer, Spring	1
Screw, Taptite, M3.5 x 6 Long, Zinc	10	Screw, Taptite, M4 x 6, Bzn	2
Sleeve, Color Tune	1	Screw, Taptite, M3.5 x 10, Bzn	1
Spring, Compression, #LC-029C-5MW, 18.5 lb.	1	Screw, Plastite, Sems, 8-11 x 5/8 Long	2
Rod, Slide	4	Screw, Plastite, Sems, Hex Washer	4
Rod, Center	1	Nut, Hex, M4, Nylon Locknut, Stl., Zinc	4
Strain Relief	1	Screw, Machine, M4 x 6 Long, Bzn	2
Screw, Plastite, 6-19 x 1 Long, Zinc	1	Retainer, Fresnel	2
Clip, Speed, Knob to Shaft	1	Spring, Cord Wrap	2
Shaft, Color Tune, International	1	Spacer, Switch	2
Screw, Taptite, Sems, M4 x 8, Zinc	4	Spring, Leaf	1
Screw, Post, Latch, Spring	2	Shaft, Pivot Actuator	1
Ring, Push-on, Truarc #511	2	Shaft, Color Tune	1
Screw, Taptite, 10-32 x 5/8 Long, Bzn	4	Screw, Machine, M4 x 0.7 x 12 Long, Zinc	2
Spring, Compression, #LC-020C-4MW	1	Screw, Machine, M4 x 0.7 x 30 Long, Zinc	2
Screw, Taptite, M3 x 10, Zinc	2	Screw, Taptite, Pan Head, M3 x 20 PN, Zinc	4
Screw, Type BT, 8-18 x 5/16 Long, Bzn	1	Spring, Compression, 0.30 O.D., 0.032W	1
Screw, Plastite, 6-19 x 3/8 Long, Bzn	12	E-Ring, Retaining	2
Nut	1		

APPENDIX A – 1800 (U.S.) SPECIFICATIONS

Model Alpha	1810 AJA	1820 AJF	1825 AJY	1830 AJE	1840 AJZ	1850 AJH
Country	United States	United States	United States	United States	United States	United States
Power Cord	Type B	Type B	Type B	Type B	Type B	Type B
Stock Number	XO-0038-0715-3	XO-0038-0712-0	XO-0038-0717-9	XO-0038-0711-2	XO-0038-0746-8	78-9236-6603-2
Voltage/Hz	120V / 60Hz	120V / 60Hz	120V / 60Hz	120V / 60Hz	120V / 60Hz	120V / 60Hz
Agency	UL / cUL	UL / cUL	UL / cUL	UL / cUL	UL / cUL	UL / cUL
Stage Size	10.5 inch	10.5 inch	10.5 inch	10.5 inch	10.5 inch	10.5 inch
Head Type	Open Singlet	Articulating Closed Singlet	Articulating Closed Singlet	Articulating Closed Doublet	Open Singlet	Inverted Head Open Singlet
Lamp Changer	No	No	No	No	Yes	No
Color Tuning	No	No	No	No	No	No
Post Type	Folding	Folding	Folding	Folding	Folding	Offset Folding
Lamp Type	ENX	ENX	FXL	ENX	ENX	ENX
Handle	No	No	No	No	No	Yes
Lamp Control	No	No	Dimmer Switch	No	No	No
Lamps Installed	1	1	1	1	1	1
Fresnel	Dual Element	Dual Element	Dual Element	Dual Element	Dual Element	Single Element
Power	Diode	Diode	Diode	Diode	Diode	Diode
Fuse	---	---	---	---	---	---
Amps	4.5	4.5	5.0	4.5	4.5	4.5
Clock	No	No	No	No	No	No
Cord Storage	Cord Wrap	Cord Wrap	Cord Wrap	Cord Wrap	Cord Wrap	Cord Wrap

APPENDIX A – 1800 (U.S.) SPECIFICATIONS (Continued)

Model Alpha	1860 AJD	1865 AJL	1870 AJG	1880 AJB	1885 AJW	1895 AJC
Country	United States	United States	United States	United States	United States	United States
Power Cord	Type B	Type B	Type B	Type B	Type B	Type B
Stock Number	XO-0038-0713-8	XO-0038-0718-7	78-9236-6584-4	XO-0038-0714-6	XO-0038-0716-1	XO-0038-0710-4
Voltage/Hz	120V / 60Hz	120V / 60Hz	120V / 60Hz	120V / 60Hz	120V / 60Hz	120V / 60Hz
Agency	UL / cUL	UL / cUL	UL / cUL	UL / cUL	UL / cUL	UL / cUL
Stage Size	10.5 inch	10.5 inch	10.5 inch	10.5 inch	10.5 inch	11.2 inch (A4)
Head Type	Articulating Closed Singlet	Articulating Closed Singlet	Inverted Head Open Singlet	Articulating Closed Doublet	Articulating Closed Doublet	Inverted Head Open Triplet
Lamp Changer	Yes	Yes	Yes	Yes	Yes	Yes
Color Tuning	Yes	Yes	No	Yes	Yes	Yes
Post Type	Folding	Folding	Offset Folding	Folding	Folding	Offset Folding
Lamp Type	ENX	FXL	ENX	ENX	FXL	FXL
Handle	Yes	Yes	Yes	Yes	Yes	Yes
Lamp Control	No	Dimmer Switch	No	Dimmer Switch	Dimmer Switch	Dimmer Switch
Lamps Installed	1	1	1	1	1	2
Fresnel	Dual Element	Dual Element	Single Element	Dual Element	Dual Element	Dual Element
Power	Diode	Diode	Diode	Diode	Diode	Diode
Fuse	---	---	---	---	---	---
Amps	4.5	5.0	4.5	4.5	5.0	5.0
Clock	No	No	Yes	Yes	Yes	Yes
Cord Storage	Cord Wrap	Cord Wrap	Cord Wrap	Cord Wrap	Cord Wrap	Cord Wrap

APPENDIX A – 1800 (O.U.S.) SPECIFICATIONS

Model Alpha	1805 ABAJ	1805 AHAD	1805 AHAI	1805 AHAN	1805 AHAS	1805 AHAU
Country	Japan	Saudi Arabia	Argentina	New Zealand	Europe Standard	United Kingdom
Power Cord	Type A	Type F	Type I	Type I	Type F	Type G
Stock Number	XO-0038-0724-5	XO-0038-0615-5	XO-0038-0616-3	XO-0038-0614-8	XO-0038-0600-7	XO-0038-0605-6
Voltage/Hz	100V / 50-60Hz	230V / 50Hz	220V / 50Hz	240V / 50Hz	230V / 50Hz	230V / 50Hz
Agency	PSE	- - -	CE-NEMKO	CE-NEMKO C-Tick	CE-NEMKO	CE-NEMKO
Stage Size	11.2 inch (A4)	11.2 inch (A4)	11.2 inch (A4)	11.2 inch (A4)	11.2 inch (A4)	11.2 inch (A4)
Head Type	Inverted Head Open Singlet	Inverted Head Open Singlet	Inverted Head Open Singlet	Inverted Head Open Singlet	Inverted Head Open Singlet	Inverted Head Open Singlet
Lamp Changer	No	No	No	No	No	No
Color Tuning	No	No	No	No	No	No
Post Type	Offset Folding	Offset Folding	Offset Folding	Offset Folding	Offset Folding	Offset Folding
Lamp Type	FNT	FNT	FNT	FNT	FNT	FNT
Handle	No	No	No	No	No	No
Lamp Control	No	No	No	No	No	No
Lamps Installed	2	2	2	2	2	2
Fresnel	Dual Element	Dual Element	Dual Element	Dual Element	Dual Element	Dual Element
Power	Transformer	Transformer	Transformer	Transformer	Transformer	Transformer
Fuse	T5A	T4A	T4A	T4A	T4A	T4A
Amps	4.0	1.6	1.6	1.6	1.6	1.6
Clock	No	No	No	No	No	No
Cord Storage	Cord Wrap	Cord Wrap	Cord Wrap	Cord Wrap	Cord Wrap	Cord Wrap

APPENDIX A – 1800 (O.U.S.) SPECIFICATIONS (Continued)

Model Alpha	1808 AADD	1808 AADT	1808 ABDJ	1808 AHDA	1808 AHDE	1808 AHDF
Country	Saudi Arabia	Taiwan	Japan	Australia	Malaysia	Thailand
Power Cord	Type B	Type A	Type A	Type I	Type G	Type F
Stock Number	XO-0038-0738-5	XO-0038-0727-8	XO-0038-0721-1	XO-0038-0617-1	XO-0038-0652-8	XO-0038-0624-7
Voltage/Hz	127V / 60Hz	120V / 60Hz	100V / 50-60Hz	240V / 50Hz	250V / 50Hz	240V / 50Hz
Agency	---	---	PSE	CE-NEMKO C-Tick	CE-NEMKO	CE-NEMKO
Stage Size	11.2 inch (A4)	11.2 inch (A4)	11.2 inch (A4)	11.2 inch (A4)	11.2 inch (A4)	11.2 inch (A4)
Head Type	Inverted Head Open Singlet	Inverted Head Open Singlet	Inverted Head Open Singlet	Inverted Head Open Singlet	Inverted Head Open Singlet	Inverted Head Open Singlet
Lamp Changer	Yes	Yes	Yes	Yes	Yes	Yes
Color Tuning	Yes	Yes	Yes	Yes	Yes	Yes
Post Type	Offset Folding	Offset Folding	Offset Folding	Offset Folding	Offset Folding	Offset Folding
Lamp Type	ENX	FNT	FNT	FNT	FNT	FNT
Handle	No	No	No	No	No	No
Lamp Control	No	Dimmer Switch	Dimmer Switch	Dimmer switch	Dimmer Switch	Dimmer Switch
Lamps Installed	1	2	2	2	2	2
Fresnel	Dual Element	Dual Element	Dual Element	Dual Element	Dual Element	Dual Element
Power	Diode	Transformer	Transformer	Transformer	Transformer	Transformer
Fuse	---	T5A	T5A	T4A	T4A	T4A
Amps	4.5	3.0	4.0	1.6	1.6	1.6
Clock	No	No	No	No	No	No
Cord Storage	Cord Wrap	Cord Wrap	Cord Wrap	Cord Wrap	Cord Wrap	Cord Wrap

APPENDIX A – 1800 (O.U.S.) SPECIFICATIONS (Continued)

Model Alpha	1808 AHDG	1808 AHDH	1808 AHDN	1808 AHDR	1808 AHDS	1808 AHDU
Country	India	Hong Kong	New Zealand	South Africa	Europe Standard	United Kingdom
Power Cord	Type D	Type G	Type I	Type D	Type F	Type G
Stock Number	XO-0038-0621-3	XO-0038-0618-9	XO-0038-0619-7	XO-0038-0622-1	XO-0038-0601-5	XO-0038-0606-4
Voltage/Hz	240V / 50Hz	220V / 50Hz	240V / 50Hz	240V / 50Hz	230V / 50Hz	230V / 50Hz
Agency	CE-NEMKO C-Tick	CE-NEMKO C-Tick	CE-NEMKO C-Tick	CE-NEMKO C-Tick	CE-NEMKO C-Tick	CE-NEMKO C-Tick
Stage Size	11.2 inch (A4)	11.2 inch (A4)	11.2 inch (A4)	11.2 inch (A4)	11.2 inch (A4)	11.2 inch (A4)
Head Type	Inverted Head Open Singlet	Inverted Head Open Singlet	Inverted Head Open Singlet	Inverted Head Open Singlet	Inverted Head Open Singlet	Inverted Head Open Singlet
Lamp Changer	Yes	Yes	Yes	Yes	Yes	Yes
Color Tuning	Yes	Yes	Yes	Yes	Yes	Yes
Post Type	Offset Folding	Offset Folding	Offset Folding	Offset Folding	Offset Folding	Offset Folding
Lamp Type	FNT	FNT	FNT	FNT	FNT	FNT
Handle	No	No	No	No	No	No
Lamp Control	Dimmer Switch	Dimmer Switch	Dimmer Switch	Dimmer Switch	Dimmer Switch	Dimmer Switch
Lamps Installed	2	2	2	2	2	2
Fresnel	Dual Element	Dual Element	Dual Element	Dual Element	Dual Element	Dual Element
Power	Transformer	Transformer	Transformer	Transformer	Transformer	Transformer
Fuse	T4A	T4A	T4A	T4A	T4A	T4A
Amps	1.6	1.6	1.6	1.6	1.6	1.6
Clock	No	No	No	No	No	No
Cord Storage	Cord Wrap	Cord Wrap	Cord Wrap	Cord Wrap	Cord Wrap	Cord Wrap

APPENDIX A – 1800 (O.U.S.) SPECIFICATIONS (Continued)

Model Alpha	1808 AHDV	1808 AHDY	1808 AHDZ	1808 ARDP	1810 AAAD	1810 AAAM
Country	Indonesia	China	Switzerland	Philippines	Gulf	Mexico
Power Cord	Type F	Type I	Type J	Type B	Type B	Type B
Stock Number	XO-0038-0625-4	XO-0038-0623-9	XO-0038-0607-2	XO-0038-0620-5	XO-0038-0726-0	XO-0038-0725-2
Voltage/Hz	220V / 50Hz	220V / 50Hz	230V / 50Hz	240V / 60Hz	127V / 60Hz	127V / 60Hz
Agency	CE-NEMKO C-Tick	CE-NEMKO C-Tick	CE-NEMKO	CE-NEMKO	- - -	NOM
Stage Size	11.2 inch (A4)	11.2 inch (A4)	11.2 inch (A4)	11.2 inch (A4)	10.5 inch ²	10,5 inch
Head Type	Inverted Head Open Singlet	Inverted Head Open Singlet	Inverted Head Open Singlet	Inverted Head Open Singlet	Open Singlet	Open Singlet
Lamp Changer	Yes	Yes	Yes	Yes	Yes	Yes
Color Tuning	Yes	Yes	Yes	Yes	Yes	Yes
Post Type	Offset Folding	Offset Folding	Offset Folding	Offset Folding	Folding	Folding
Lamp Type	FNT	FNT	FNT	FNT	ENX	ENX
Handle	No	No	No	No	No	No
Lamp Control	Dimmer Switch	Dimmer Switch	Dimmer Switch	Dimmer Switch	Dimmer Switch	Dimmer Switch
Lamps Installed	2	2	2	2	1	1
Fresnel	Dual Element	Dual Element	Dual Element	Dual Element	Dual Element	Dual Element
Power	Transformer	Transformer	Transformer	Transformer	Diode	Diode
Fuse	T4A	T4A	T4A	T4A	- - -	- - -
Amps	1.6	1.6	1.6	1.6	3.0	4,5
Clock	No	No	No	No	No	No
Cord Storage	Cord Wrap	Cord Wrap	Cord Wrap	Cord Wrap	Cord Wrap	Cord Wrap

APPENDIX A – 1800 (O.U.S.) SPECIFICATIONS (Continued)

Model Alpha	1810 ABBJ	1810 AHBA	1810 AHBC	1810 AHBF	1810 AHBH	1810 AHBK
Country	Japan	Australia	Chile	Thailand	Hong Kong	Korea
Power Cord	Type A	Type I	Type L	Type F	Type G	Type F
Stock Number	XO-0038-0737-7	XO-0038-0627-0	XO-0038-0632-0	XO-0038-0631-2	XO-0038-0628-8	XO-0038-0634-6
Voltage/Hz	100V / 50-60Hz	240V / 50Hz	230V / 50Hz	240V / 50Hz	220V / 50Hz	220V / 60Hz
Agency	PSE	CE-NEMKO C-Tick	CE-NEMKO	CE-NEMKO	CE-NEMKO	CE-NEMKO
Stage Size	11.2 inch (A4)	11.2 inch (A4)	11.2 inch (A4)	11.2 inch (A4)	11.2 inch (A4)	11.2 inch (A4)
Head Type	Closed Doublet	Articulating Closed Doublet	Articulating Closed Doublet	Articulating Closed Doublet	Articulating Closed Doublet	Articulating Closed Doublet
Lamp Changer	Yes	Yes	Yes	Yes	Yes	Yes
Color Tuning	Yes	Yes	Yes	Yes	Yes	Yes
Post Type	Folding	Folding	Folding	Folding	Folding	Folding
Lamp Type	FNT	FNT	FNT	FNT	FNT	FNT
Handle	Yes	Yes	Yes	Yes	Yes	Yes
Lamp Control	Dimmer Switch	Dimmer Switch	Dimmer Switch	Dimmer Switch	Dimmer Switch	Dimmer Switch
Lamps Installed	2	2	2	2	2	2
Fresnel	Dual Element	Dual Element	Dual Element	Dual Element	Dual Element	Dual Element
Power	Transformer	Transformer	Transformer	Transformer	Transformer	Transformer
Fuse	T5A	T4A	T4A	T4A	T4A	T4A
Amps	4.0	1.6	1.6	1.6	1.6	1.6
Clock	Yes	No	No	No	No	No
Cord Storage	Cord Wrap	Cord Wrap	Cord Wrap	Cord Wrap	Cord Wrap	Cord Wrap

APPENDIX A – 1800 (O.U.S.) SPECIFICATIONS (Continued)

Model Alpha	1810 AHBN	1810 AHBS	1810 AHBU	1810 AHBY	1810 AKA	1820 AACT
Country	New Zealand	Europe Standard	United Kingdom	China	Canada	Taiwan
Power Cord	Type I	Type F	Type G	Type I	Type B	Type A
Stock Number	XO-0038-0629-6	XO-0038-0602-3	XO-0038-0630-4	XO-0038-0633-8	XO-0038-0732-8	XO-0038-0740-1
Voltage/Hz	240V / 50Hz	230V / 50Hz	230V / 50Hz	220V / 50Hz	120V / 60Hz	120V / 60Hz
Agency	CE-NEMKO C-Tick	CE-NEMKO	CE-NEMKO	CE-NEMKO	UL / cUL	---
Stage Size	11.2 inch (A4)	11.2 inch (A4)	11.2 inch (A4)	11.2 inch (A4)	10.5 inch	11.2 inch (A4)
Head Type	Articulating Closed Doublet	Articulating Closed Doublet	Articulating Closed Doublet	Articulating Closed Doublet	Open Singlet	Inverted Head Open Triplet
Lamp Changer	Yes	Yes	Yes	Yes	Yes	Yes
Color Tuning	Yes	Yes	Yes	Yes	Yes	Yes
Post Type	Folding	Folding	Folding	Folding	Folding	Offset Folding
Lamp Type	FNT	FNT	FNT	FNT	ENX	FNT
Handle	Yes	Yes	Yes	Yes	No	Yes
Lamp Control	Dimmer Switch	Dimmer Switch	Dimmer Switch	Dimmer Switch	Dimmer Switch	Dimmer Switch
Lamps Installed	2	2	2	2	1	2
Fresnel	Dual Element	Dual Element	Dual Element	Dual Element	Dual Element	Dual Element
Power	Transformer	Transformer	Transformer	Transformer	Diode	Transformer
Fuse	T4A	T4A	T4A	T4A	---	T4A
Amps	1.6	1.6	1.6	1.6	4.5	3.0
Clock	No	No	No	No	No	Yes
Cord Storage	Cord Wrap	Cord Wrap	Cord Wrap	Cord Wrap	Cord Wrap	Cord Wrap

APPENDIX A – 1800 (O.U.S.) SPECIFICATIONS (Continued)

Model Alpha	1820 ABCJ	1820 AHCA	1820 AHCC	1820 AHCE	1820 AHCF	1820 AHCH
Country	Japan	Australia	Chile	Malaysia	Thailand	Hong Kong
Power Cord	Type A	Type I	Type L	Type G	Type F	Type G
Stock Number	XO-0038-0739-3	XO-0038-0635-3	XO-0038-0640-3	XO-0038-0642-9	XO-0038-0641-1	XO-0038-0636-1
Voltage/Hz	100V / 50-60Hz	240V / 50Hz	230V / 50Hz	250V / 50Hz	240V / 50Hz	220V / 50Hz
Agency	PSE	CE-NEMKO C-Tick	CE-NEMKO	CE-NEMKO	CE-NEMKO	CE-NEMKO
Stage Size	11.2 inch (A4)	11.2 inch (A4)	11.2 inch (A4)	11.2 inch (A4)	11.2 inch (A4)	11.2 inch (A4)
Head Type	Inverted Head Open Triplet	Inverted Head Open Triplet	Inverted Head Open Triplet	Inverted Head Open Triplet	Inverted Head Open Triplet	Inverted Head Open Triplet
Lamp Changer	Yes	Yes	Yes	Yes	Yes	Yes
Color Tuning	Yes	Yes	Yes	Yes	Yes	Yes
Post Type	Offset Folding	Offset Folding	Offset Folding	Offset Folding	Offset Folding	Offset Folding
Lamp Type	FNT	FNT	FNT	FNT	FNT	FNT
Handle	Yes	Yes	Yes	Yes	Yes	Yes
Lamp Control	Dimmer Switch	Dimmer Switch	Dimmer Switch	Dimmer Switch	Dimmer Switch	Dimmer Switch
Lamps Installed	2	2	2	2	2	2
Fresnel	Dual Element	Dual Element	Dual Element	Dual Element	Dual Element	Dual Element
Power	Transformer	Transformer	Transformer	Transformer	Transformer	Transformer
Fuse	T5A	T4A	T4A	T4A	T4A	T4A
Amps	4.0	1.6	1.6	1.6	1.6	1.6
Clock	Yes	Yes	Yes	Yes	Yes	Yes
Cord Storage	Cord Wrap	Cord Wrap	Cord Wrap	Cord Wrap	Cord Wrap	Cord Wrap

APPENDIX A – 1800 (O.U.S.) SPECIFICATIONS (Continued)

Model Alpha	1820 AHCK	1820 AHCN	1820 AHCR	1820 AHCS	1820 AHCU	1820 AHCY
Country	Korea	New Zealand	South Africa	Europe Standard	United Kingdom	China
Power Cord	Type F	Type I	Type D	Type F	Type G	Type I
Stock Number	XO-0038-0644-5	XO-0038-0637-9	XO-0038-0639-5	XO-0038-0603-1	XO-0038-0608-0	XO-0038-0643-7
Voltage/Hz	220V / 60Hz	240V / 50Hz	240V / 50Hz	230V / 50Hz	230V / 50Hz	220V / 50Hz
Agency	CE-NEMKO	CE-NEMKO C-Tick	CE-NEMKO C-Tick	CE-NEMKO C-Tick	CE-NEMKO C-Tick	CE-NEMKO C-Tick
Stage Size	11.2 inch (A4)	11.2 inch (A4)	11.2 inch (A4)	11.2 inch (A4)	11.2 inch (A4)	11.2 inch (A4)
Head Type	Inverted Head Open Triplet	Inverted Head Open Triplet	Inverted Head Open Triplet	Inverted Head Open Triplet	Inverted Head Open Triplet	Inverted Head Open Triplet
Lamp Changer	Yes	Yes	Yes	Yes	Yes	Yes
Color Tuning	Yes	Yes	Yes	Yes	Yes	Yes
Post Type	Offset Folding	Offset Folding	Offset Folding	Offset Folding	Offset Folding	Offset Folding
Lamp Type	FNT	FNT	FNT	FNT	FNT	FNT
Handle	Yes	Yes	Yes	Yes	Yes	Yes
Lamp Control	Dimmer Switch	Dimmer Switch	Dimmer Switch	Dimmer Switch	Dimmer Switch	Dimmer Switch
Lamps Installed	2	2	2	2	2	2
Fresnel	Dual Element	Dual Element	Dual Element	Dual Element	Dual Element	Dual Element
Power	Transformer	Transformer	Transformer	Transformer	Transformer	Transformer
Fuse	T4A	T4A	T4A	T4A	T4A	T4A
Amps	1.6	1.6	1.6	1.6	1.6	1.6
Clock	Yes	Yes	Yes	Yes	Yes	Yes
Cord Storage	Cord Wrap	Cord Wrap	Cord Wrap	Cord Wrap	Cord Wrap	Cord Wrap

APPENDIX A – 1800 (O.U.S.) SPECIFICATIONS (Continued)

Model Alpha	1820 AHCZ	1820 ARCP	1825 AAYM	1825 AKY	1830 AAEM	1830 AKE
Country	Switzerland	Philippines	Mexico	Canada	Mexico	Canada
Power Cord	Type J	Type B	Type B	Type B	Type B	Type B
Stock Number	XO-0038-0609-8	XO-0038-0638-7	XO-0038-0720-3	XO-0038-0734-4	XO-0038-0719-5	XO-0038-0733-6
Voltage/Hz	230V / 50Hz	240V / 60Hz	127V / 60Hz	120V / 60Hz	127V / 60Hz	120V / 60Hz
Agency	CE-NEMKO C-Tick	CE-NEMKO	NOM	UL / cUL	NOM	UL / cUL
Stage Size	11.2 inch (A4)	11.2 inch (A4)	10,5 inch	10.5 inch	10,5 inch	10.5 inch
Head Type	Inverted Head Open Triplet	Inverted Head Open Triplet	Articulating Closed Singlet	Articulating Closed Singlet	Articulating Closed Doublet	Articulating Closed Doublet
Lamp Changer	Yes	Yes	No	No	No	No
Color Tuning	Yes	Yes	No	No	No	No
Post Type	Offset Folding	Offset Folding	Folding	Folding	Folding	Folding
Lamp Type	FNT	FNT	FXL	FXL	ENX	ENX
Handle	Yes	Yes	No	No	No	No
Lamp Control	Dimmer Switch	Dimmer Switch	Dimmer Switch	Dimmer Switch	Dimmer Switch	Dimmer Switch
Lamps Installed	2	2	1	1	1	1
Fresnel	Dual Element	Dual Element	Dual Element	Dual Element	Dual Element	Dual Element
Power	Transformer	Transformer	Diode	Diode	Diode	Diode
Fuse	T4A	T4A	---	---	---	---
Amps	1.6	1.6	5,0	5.0	4,5	4.5
Clock	Yes	Yes	No	No	No	No
Cord Storage	Cord Wrap	Cord Wrap	Cord Wrap	Cord Wrap	Cord Wrap	Cord Wrap

APPENDIX A – 1800 (O.U.S.) SPECIFICATIONS (Continued)

Model Alpha	1850 AHRA	1850 AHRE	1850 AHRF	1850 AHRJ	1850 AHRK	1850 AHRS
Country	New Zealand/ Australia	Malaysia	Thailand	Japan	Korea	Europe Standard
Power Cord	Type I	Type G	Type F	Type A	Type F	Type F
Stock Number	XO-0038-0648-6	XO-0038-0653-6	XO-0038-0646-0	XO-0038-0747-6	XO-0038-0647-8	XO-0038-0604-9
Voltage/Hz	240V / 50Hz	250V / 50Hz	240V / 50Hz	100V / 50Hz	220V / 60Hz	230V / 50Hz
Agency	CE-NEMKO C-Tick	CE-NEMKO	CE-NEMKO	PSE	CE-NEMKO	CE-NEMKO
Stage Size	11.2 inch (A4)	11.2 inch (A4)	11.2 inch (A4)	11.2 inch (A4)	11.2 inch (A4)	11.2 inch (A4)
Head Type	Inverted Head Open Triplet	Inverted Head Open Triplet	Inverted Head Open Triplet	Inverted Head Open Triplet	Inverted Head Open Triplet	Inverted Head Open Triplet
Lamp Changer	Yes	Yes	Yes	Yes	Yes	Yes
Color Tuning	Yes	Yes	Yes	Yes	Yes	Yes
Post Type	Offset Folding	Offset Folding	Offset Folding	Offset Folding	Offset Folding	Offset Folding
Lamp Type	EVD	EVD	EVD	EVD	EVD	EVD
Handle	Yes	Yes	Yes	Yes	Yes	Yes
Lamp Control	Dimmer Switch	Dimmer Switch	Dimmer switch	Dimmer switch	Dimmer switch	Dimmer switch
Lamps Installed	2	2	2	2	2	2
Fresnel	Dual Element	Dual Element	Dual Element	Dual Element	Dual Element	Dual Element
Power	Transformer	Transformer	Transformer	Transformer	Transformer	Transformer
Fuse	T5A	T5A	T5A	T5A	T5A	T5A
Amps	2.5	2.5	2.5	5.0	2.5	2.5
Clock	Yes	Yes	Yes	Yes	Yes	Yes
Cord Storage	Cord Wrap	Cord Wrap	Cord Wrap	Cord Wrap	Cord Wrap	Cord Wrap

APPENDIX A – 1800 (O.U.S.) SPECIFICATIONS (Continued)

Model Alpha	1850 AHRU	1850 AHRV	1850 AHRZ	1850 AKH	1850 ARRP	1860 AKD
Country	United Kingdom	Indonesia	Switzerland	Canada	Philippines	Canada
Power Cord	Type G	Type F	Type J	Type B	Type B	Type B
Stock Number	XO-0038-0611-4	XO-0038-0650-2	XO-0038-0613-0	XO-0038-0743-5	XO-0038-0651-0	XO-0038-0735-1
Voltage/Hz	230V / 50Hz	220V / 50Hz	230V / 50Hz	120V / 60Hz	240V / 50Hz	120V / 60Hz
Agency	CE-NEMKO	CE-NEMKO	CE-NEMKO	UL / cUL	CE-NEMKO	UL / cUL
Stage Size	11.2 inch (A4)	11.2 inch (A4)	11.2 inch (A4)	10.5 inch	11.2 inch (A4)	10.5 inch
Head Type	Inverted Head Open Triplet	Inverted Head Open Triplet	Inverted Head Open Triplet	Inverted Head Open Triplet	Inverted Head Open Triplet	Articulated Closed Singlet
Lamp Changer	Yes	Yes	Yes	Yes	Yes	Yes
Color Tuning	Yes	Yes	Yes	Yes	Yes	Yes
Post Type	Offset Folding	Offset Folding	Offset Folding	Offset Folding	Offset Folding	Folding
Lamp Type	EVD	EVD	EVD	ENX	EVD	ENX
Handle	Yes	Yes	Yes	Yes	Yes	Yes
Lamp Control	Dimmer switch	Dimmer Switch	Dimmer switch	Dimmer Switch	Dimmer Switch	Dimmer Switch
Lamps Installed	2	2	2	1	2	1
Fresnel	Dual Element	Dual Element	Dual Element	Single Element	Dual Element	Dual Element
Power	Transformer	Transformer	Transformer	Diode	Transformer	Diode
Fuse	T5A	T5A	T5A	- - -	T5A	- - -
Amps	2.5	2.5	2.5	4.5	2.5	4.5
Clock	Yes	Yes	Yes	Yes	Yes	No
Cord Storage	Cord Wrap	Cord Wrap	Cord Wrap	Cord Wrap	Cord Wrap	Cord Wrap

APPENDIX A – 1800 (O.U.S.) SPECIFICATIONS (Continued)

Model Alpha	1865 AALM	1865 AKW	1870 AAGB	1870 AAGM	1880 AABM	1880 AKB
Country	Mexico	Canada	Brazil	Mexico	Mexico	Canada
Power Cord	Type B	Type B	Type B	Type B	Type B	Type B
Stock Number	XO-0038-0729-4	XO-0038-0722-9	XO-0038-0741-9	XO-0038-0742-7	XO-0038-0730-2	XO-0038-0723-7
Voltage/Hz	127V / 60Hz	120V / 60Hz	120V / 60Hz	127V / 60Hz	127V / 60Hz	120V / 60Hz
Agency	NOM	UL / cUL	- - -	NOM	NOM	UL / cUL
Stage Size	10,5 inch	10.5 inch	10.5 inch	10,5 inch	10,5 inch	10.5 inch
Head Type	Articulated Closed Singlet	Articulated Closed Singlet	Inverted Head Open Singlet	Inverted Head Open Singlet	Articulated Closed Doublet	Articulated Closed Doublet
Lamp Changer	Yes	Yes	Yes	Yes	Yes	Yes
Color Tuning	Yes	Yes	No	No	Yes	Yes
Post Type	Folding	Folding	Offset Folding	Offset Folding	Folding	Folding
Lamp Type	FXL	FXL	ENX	ENX	ENX	ENX
Handle	Yes	Yes	Yes	Yes	Yes	Yes
Lamp Control	Dimmer Switch	Dimmer Switch	Dimmer Switch	Dimmer switch	Dimmer Switch	Dimmer Switch
Lamps Installed	1	1	1	1	1	1
Fresnel	Dual Element	Dual Element	Single Element	Single Element	Dual Element	Dual Element
Power	Diode	Diode	Diode	Diode	Diode	Diode
Fuse	- - -	- - -	- - -	- - -	- - -	- - -
Amps	5,0	5.0	4.5	4,5	4,5	4.5
Clock	No	No	Yes	Yes	Yes	Yes
Cord Storage	Cord Wrap	Cord Wrap	Cord Wrap	Cord Wrap	Cord Wrap	Cord Wrap

APPENDIX A – 1800 (O.U.S.) SPECIFICATIONS (Continued)

Model Alpha	1895 AACM	1895 AKC
Country	Mexico	Canada
Power Cord	Type B	Type B
Stock Number	XO-0038-0731-0	XO-0038-0736-9
Voltage/Hz	127V / 60Hz	120V / 60Hz
Agency	NOM	UL / cUL
Stage Size	11,2 inch (A4)	11.2 inch (A4)
Head Type	Inverted Head Open Triplet	Inverted Head Open Triplet
Lamp Changer	Yes	Yes
Color Tuning	Yes	Yes
Post Type	Offset Folding	Offset Folding
Lamp Type	FXL	FXL
Handle	Yes	Yes
Lamp Control	Dimmer Switch	Dimmer Switch
Lamps Installed	2	2
Fresnel	Dual Element	Dual Element
Power	Diode	Diode
Fuse	- - -	- - -
Amps	5,0	5.0
Clock	Yes	Yes
Cord Storage	Cord Wrap	Cord Wrap

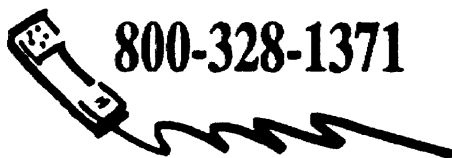

<http://www.3M.com/meetings>

Copyrights

The 3M logo, and 3M are a trademark of 3M Company.

Important Notice

All statements, technical information, and recommendations related to the service, repair or operation of 3M products are believed to be reliable, but the accuracy or completeness is not guaranteed and based on information provided to us. Before implementation, you must evaluate them and determine if they are suitable for your intended application or situation. You assume all risks and liability associated with such implementation.

Warranty; Limited Remedy; Limited Liability

3M's product warranty is stated in its Product Literature available upon request. **3M MAKES NO OTHER WARRANTIES INCLUDING, BUT NOT LIMITED TO, ANY IMPLIED WARRANTY OF MERCHANTABILITY OR FITNESS FOR A PARTICULAR PURPOSE.** If this product is defective within the warranty period stated in the Product Literature, your exclusive remedy shall be, at 3M's option, to replace or repair the 3M product or refund the purchase price of the 3M product. **Except where prohibited by law, 3M will not be liable for any loss or damage arising from this 3M product, whether indirect, special, incidental or consequential regardless of the legal theory asserted.**